

Birlea

Suppliers of inspiration

Assembly Instructions

*Thank you for
purchasing a
Birlea product.*

For a chance to win a *Love 2 Shop* voucher simply post a picture of your new product on your preferred social channels tagging Birlea Furniture and using the hashtag **#ShareYourStyle** and **#Birlea**. One winner will be selected at random each month.

To view our full terms and conditions please visit our website. www.birlea.com

Are you happy with your purchase?

Yes: That's great, we would love to hear more from you. Please leave us a review on our social media channels or Trustpilot. Your feedback will be greatly appreciated.

No: If for any reason there is something missing, indifferent or incorrect with your order, please contact the retailer you purchased the item from. We will work with the retailer to resolve your issue as quickly as possible.



www.birlea.com

ASSEMBLY INSTRUCTIONS **HOUSTON 6 DRAWER CHEST**

IMPORTANT : READ THESE INSTRUCTIONS CAREFULLY BEFORE ATTEMPTING TO ASSEMBLE OR USE YOUR HOUSTON 6 DRAWER CHEST.

PLEASE KEEP THESE INSTRUCTIONS FOR FUTURE REFERENCE.

ASSEMBLY:

Assembly should be carried out with this item laying flat, not standing upright.

Assemble on a soft, clean surface to prevent damages.

To erase the numbers printed on the pieces, use the rubber inside the accessories pack.

HEALTH & SAFETY:

DO NOT use this product if any parts are missing, damaged or worn.

DO NOT use this product unless all fixings are secured.

Always use on a level, even surface.

CARE & MAINTENANCE:

Periodically check all screws & fixings to ensure they are secure.

DO NOT push this product as this will cause damage.

Always lift this product with two people to repositions.

Keep any sharp objects away from this product.

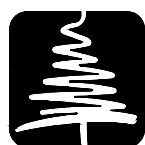
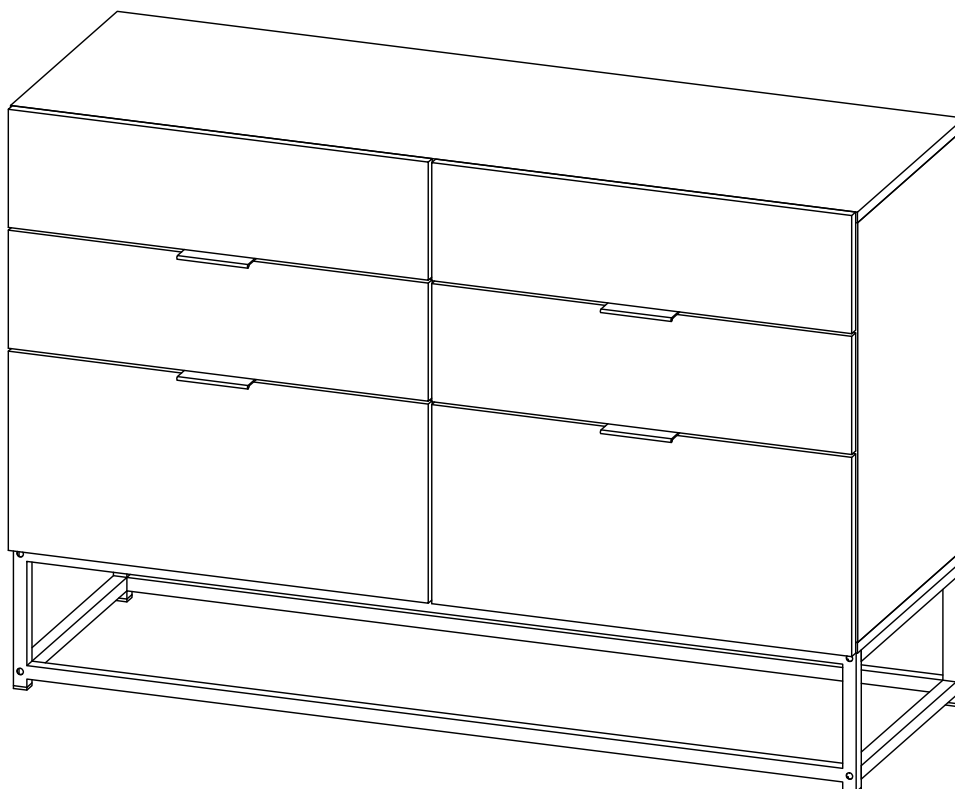



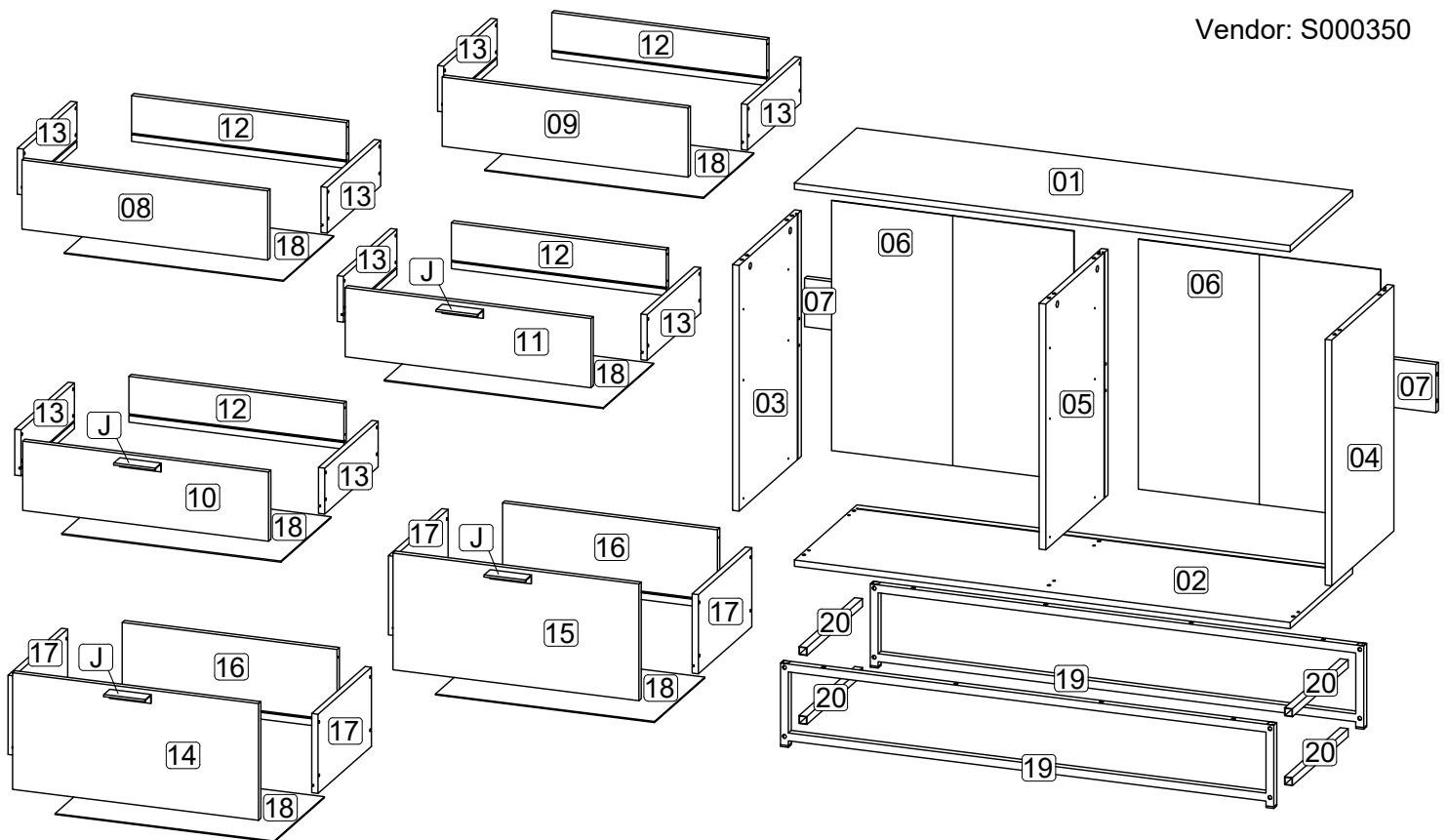

Birlea

Suppliers of inspiration

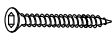
www.birlea.com



Parts List				Hardware List (BOX 2)			
Part	Description	Box	Qty	Part	Description		Qty
01	Top panel	1	1	A1	Cam lock		14
02	Bottom panel	1	1	A2	Minifix screw		14
03	Side panel (Left)	1	1	A3	Plastic cap		14
04	Side panel (Right)	1	1	B	M8 x 30mm Wood Dowel		12
05	Center panel	1	1	C	M6 x 50mm CSK Cap Wood screw		6
06	Back panel	1	2	D	Allen key M4		1
07	Back bone (L/R)	1	2	E	M3 x 12mm C.B Screw		8
08	Drawer front (Up Left)	2	1	F	M3.5 x 16mm C.B Screw		74
09	Drawer front (Up Right)	2	1	G	M4 x 38mm C.B Screw		48
10	Drawer front (Middle Left)	2	1	H	JCBC screw M6 x 30mm		8
11	Drawer front (Middle Right)	2	1	I	JCBC screw M6 x 40mm		8
12	Drawer back (Up)	2	4	J	4020 L Bar 100mm		4
13	Drawer side (Up)	2	8	K1	Stud 192		8
14	Drawer front (Down Left)	2	1	K2	Stud 192 screw		8
15	Drawer front (Down Right)	2	1	L1	14" Drawer slide (Left / Right)		12
16	Drawer back (Down)	2	2	L2	14" Drawer slide (Left / Right)		12
17	Drawer side (Down)	2	4	M	8" x 1" PP tape		2
18	Drawer bottom	2	6	N	Wall plug		-
19	Metal frame	1	2	** You will need a small mallet and a screwdriver for assembly. ** Some screws and wooden dowel may remain. ** Note : To secure the item to the wall, hardware G (2 pcs) and N (2 pcs) are not provided.			
20	Metal bone	1	4				

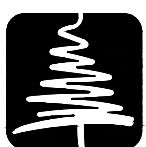

Birlea

Suppliers of inspiration

Step 1: Prepare these parts for assembly using hardware parts A1, A2, B, D, F and L1.

DO NOT use any power tools as this may damage the frame and will invalidate any claim.

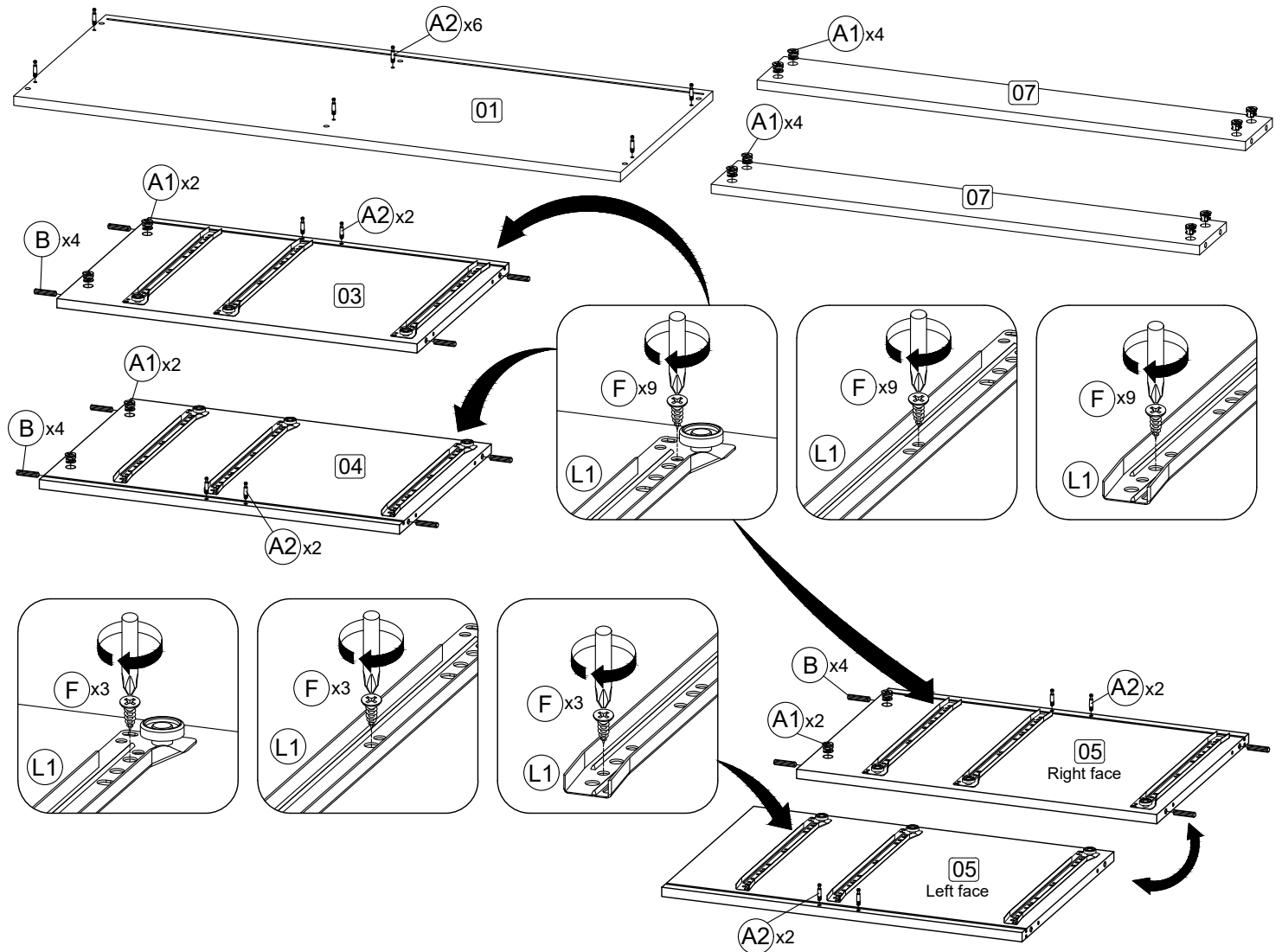

Step 2: Attach back bone (7) to side panel (3) and center panel (5) using hardware A1 and A2 with a screwdriver (not provided).

Attach back bone (7) to side panel (4) and center panel (5) using hardware A1 and A2 with a screwdriver (not provided).

DO NOT use any power tools as this may damage the frame and will invalidate any claim.

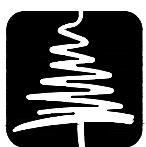
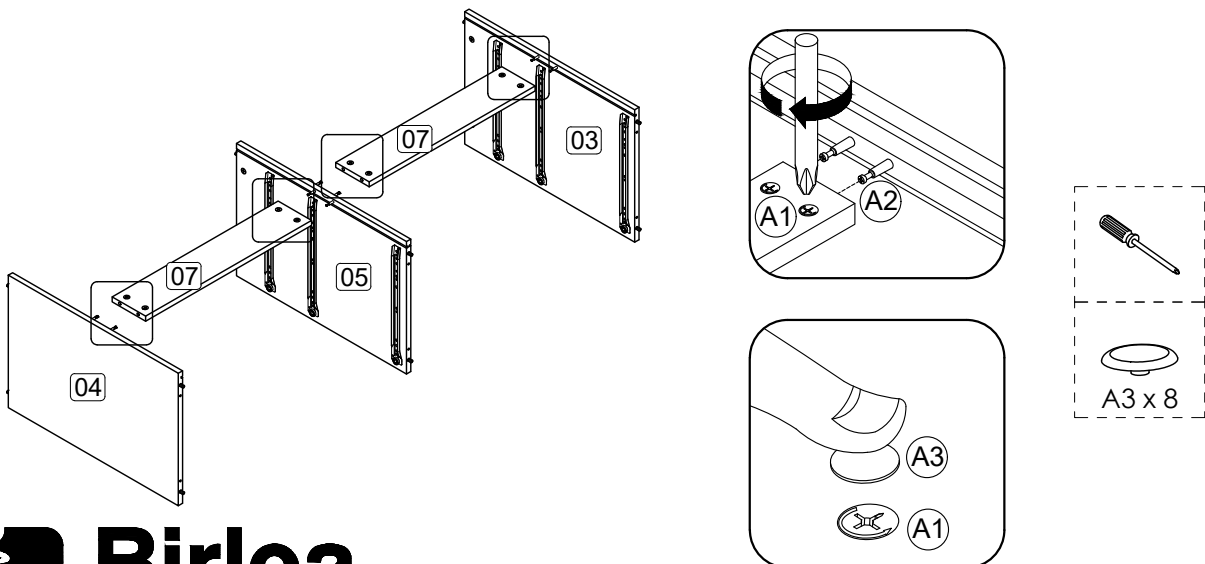

Birlea

Suppliers of inspiration

Step 3: Attach side panel (3), (4) and center panel (5) to top panel (1) using hardware A1 and A2 with a screwdriver (not provided).

DO NOT use any power tools as this may damage the frame and will invalidate any claim.

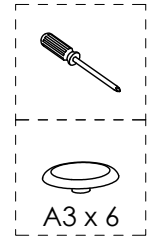
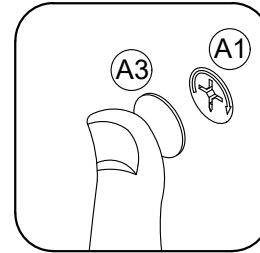
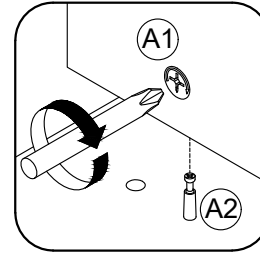
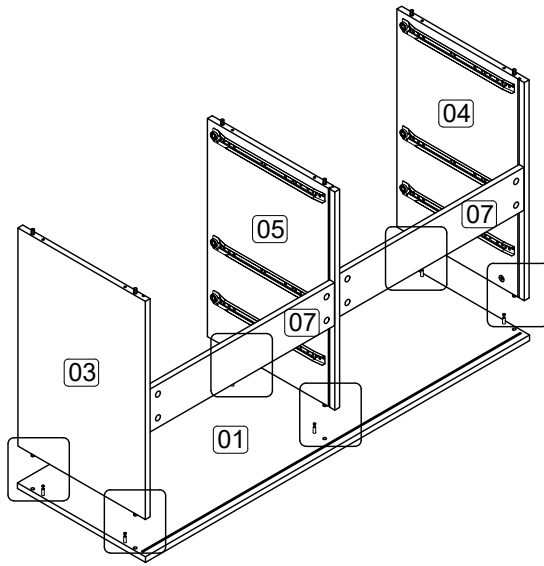

Step 4: Insert back panel (6) along the slot.

DO NOT use any power tools as this may damage the frame and will invalidate any claim.

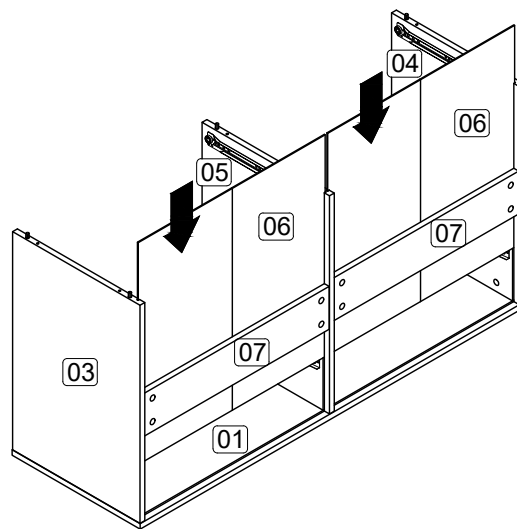

Step 5: Attach bottom panel (2) to side panel (3), (4) and center panel (5) using hardware C and D.

DO NOT use any power tools as this may damage the frame and will invalidate any claim.

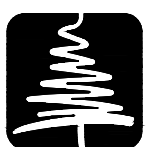
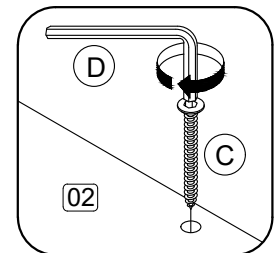
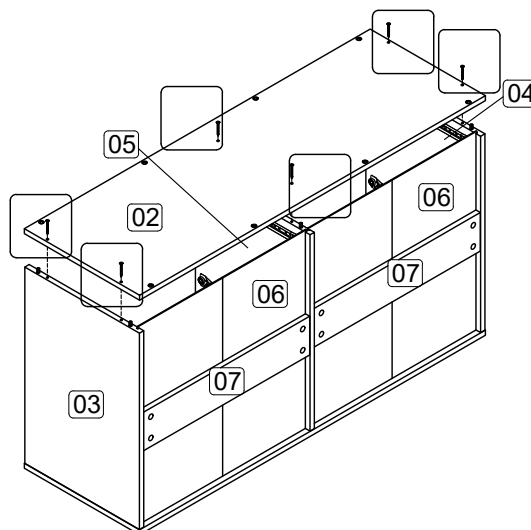
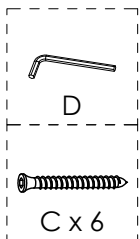

Birlea

Suppliers of inspiration

Step 6: Attach hardware K1 into top panel (1), bottom panel (2), side panel (3) and (4) using hardware K2 with a screwdriver (not provided).
DO NOT use any power tools as this may damage the frame and will invalidate any claim.

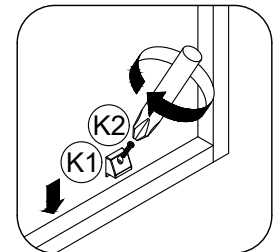
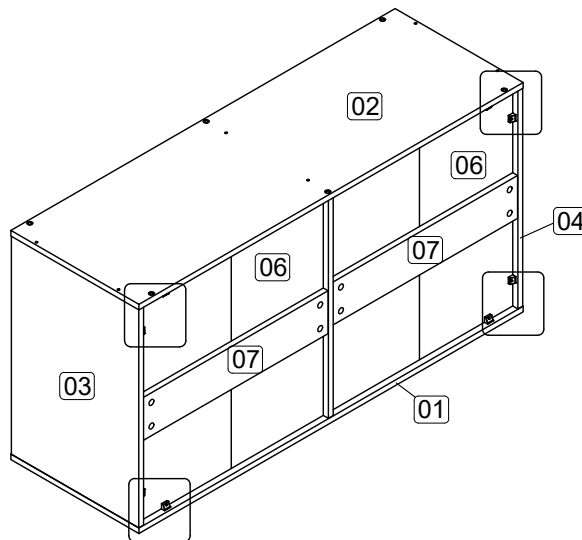
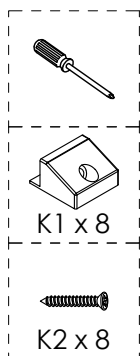

Step 7: Attach metal frame (19) to metal bone (20) using hardware D and I.
DO NOT use any power tools as this may damage the frame and will invalidate any claim.

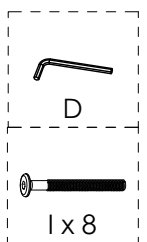
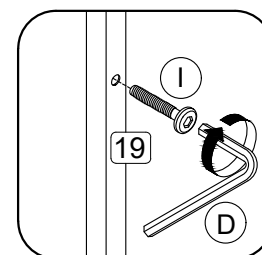
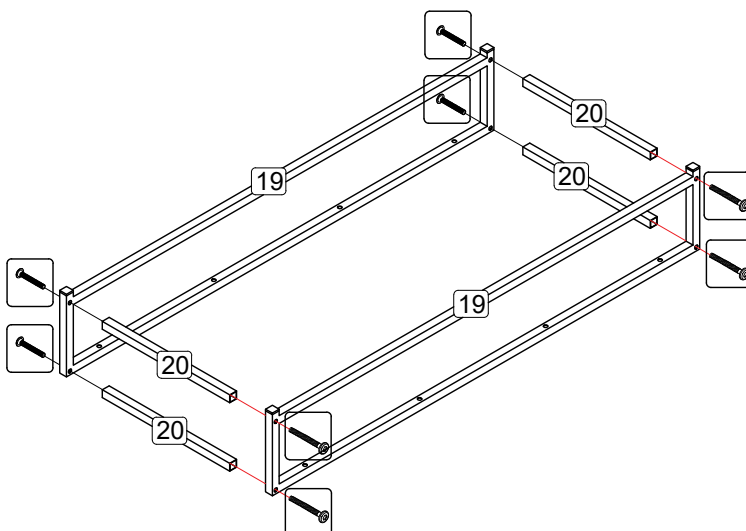

Step 8: Attach metal frame (19) to bottom panel (2) using hardware D and H.
DO NOT use any power tools as this may damage the frame and will invalidate any claim.

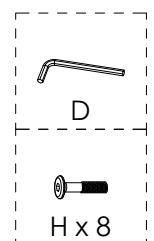
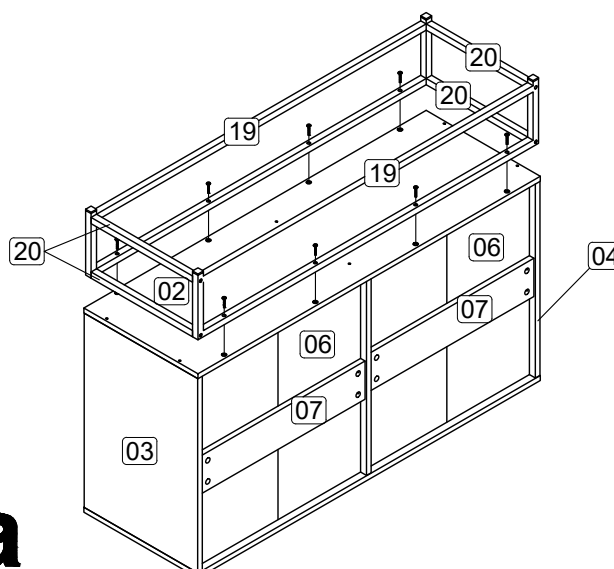
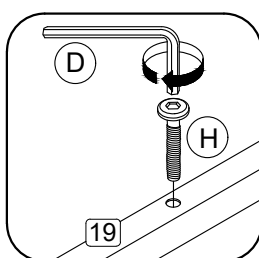

Step 9: Assemble the drawer components using hardware F, G and L2.

In this step only show one of the drawers.

DO NOT use any power tools as this may damage the frame and will invalidate any claim.

Smaller drawers

1. Attach drawer side (up) (13) to drawer back (up) (12) and drawer front (up) (8) or (9) using hardware part (G).
2. Slide in drawer bottom (18) then attach drawer side (up) (13) using hardware part (G).
3. Attach hardware part (L2) to drawer sides (up) (13) using hardware part (F).

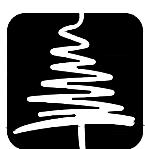
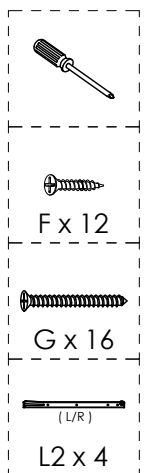
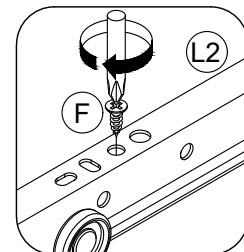
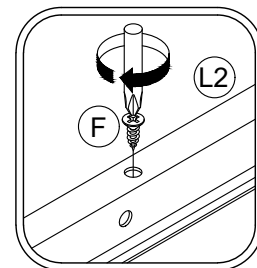
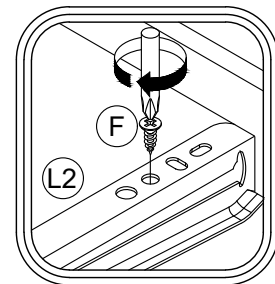
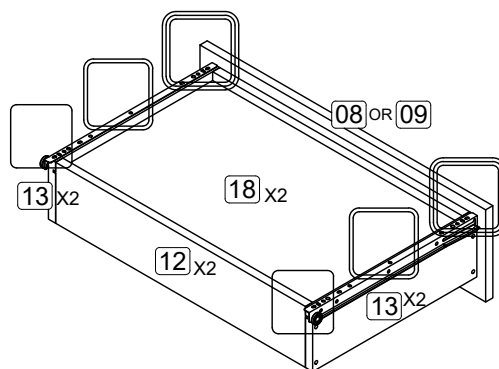
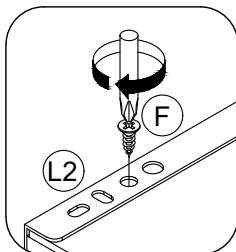
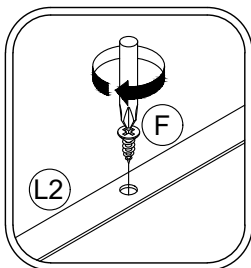
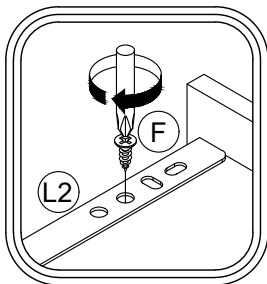
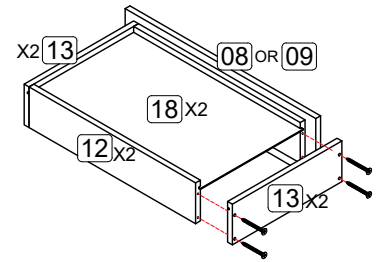
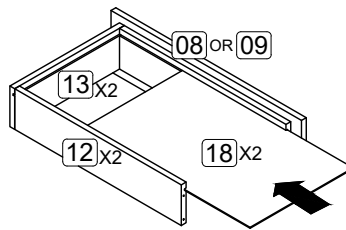
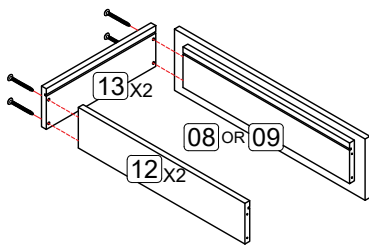

Birlea

Suppliers of inspiration

Step 10: Assemble the drawer components using hardware E, F, G, J and L2.

In this step only show one of the drawers.

DO NOT use any power tools as this may damage the frame and will invalidate any claim.

Smaller drawers

1. Insert Hardware part (J) to drawer front (middle) (10) or (11) using hardware part (E)
2. Attach drawer side (up) (13) to drawer back (up) (12) and drawer front (middle) (10) or (11) using hardware part (G).
3. Slide in drawer bottom (18) then attach drawer side (up) (13) using hardware part (G).
4. Attach hardware part (L2) to drawer sides (up) (13) using hardware part (F).

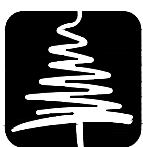
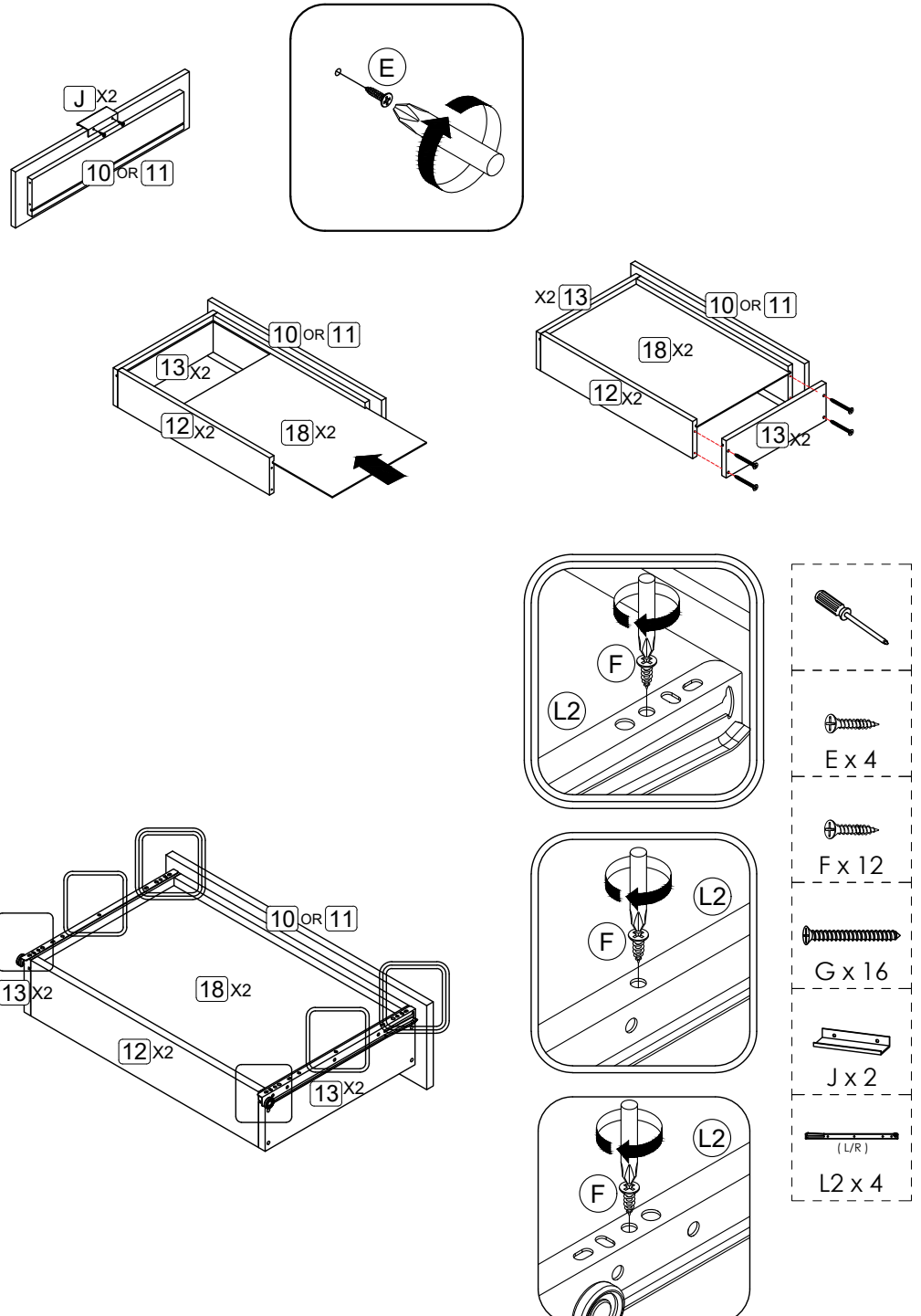

Birlea

Suppliers of inspiration

Step 11: Assemble the drawer components using hardware E, F, G, J and L2.

In this step only show one of the drawers.

DO NOT use any power tools as this may damage the frame and will invalidate any claim.

Larger drawers

1. Insert Hardware part (J) to drawer front (down) (14) or (15) using hardware part (E)
2. Attach drawer side (down) (17) to drawer back (down) (16) and drawer front (down) (14) or (15) using hardware part (G).
3. Slide in drawer bottom (18) then attach drawer side (down) (17) using hardware part (G).
4. Attach hardware part (L2) to drawer sides (17) using hardware part (F).

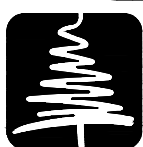
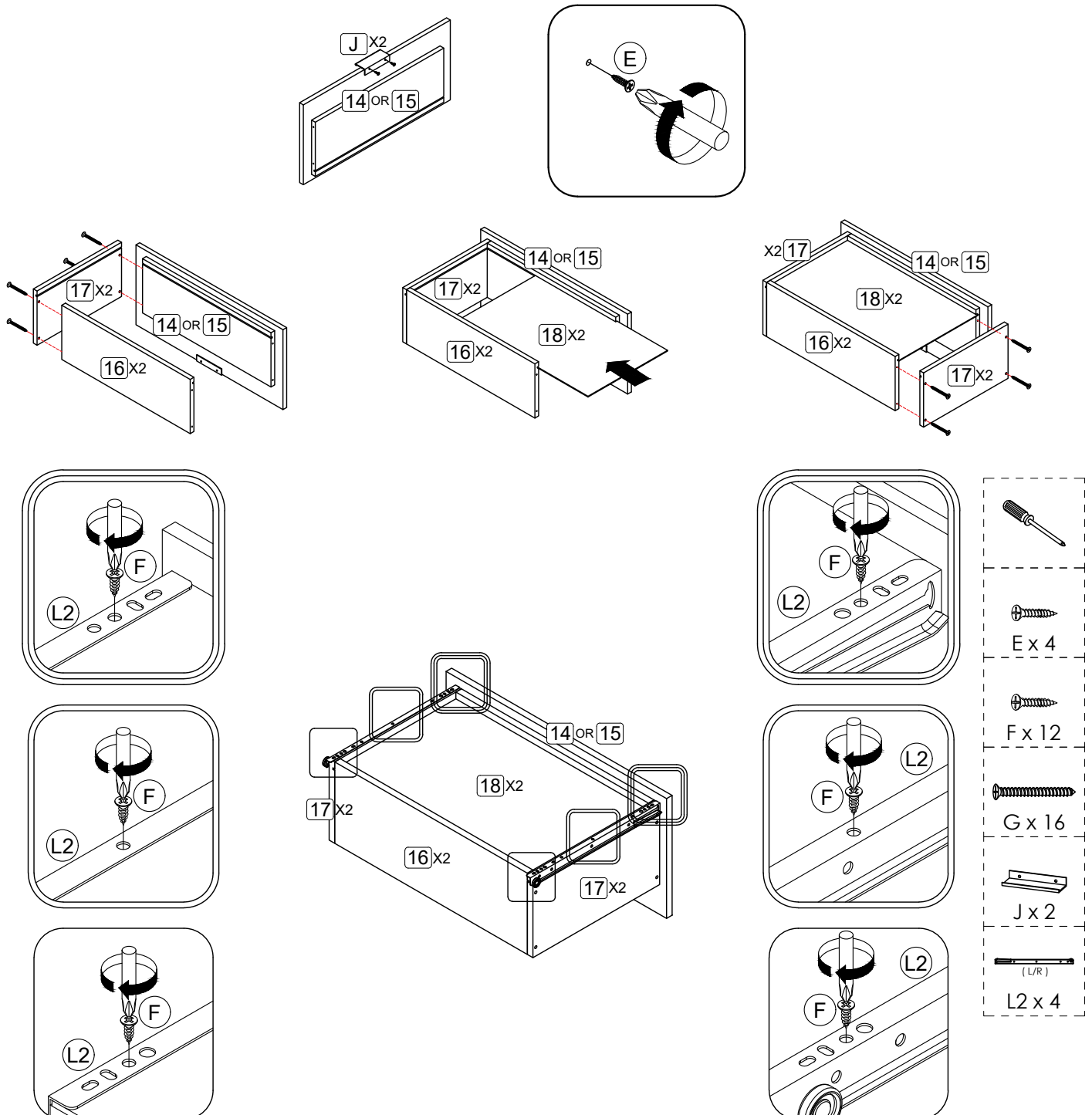

Birlea

Suppliers of inspiration

Step 12: Assemble the drawers in place along the drawer slides.

DO NOT use any power tools as this may damage the frame and will invalidate any claim.

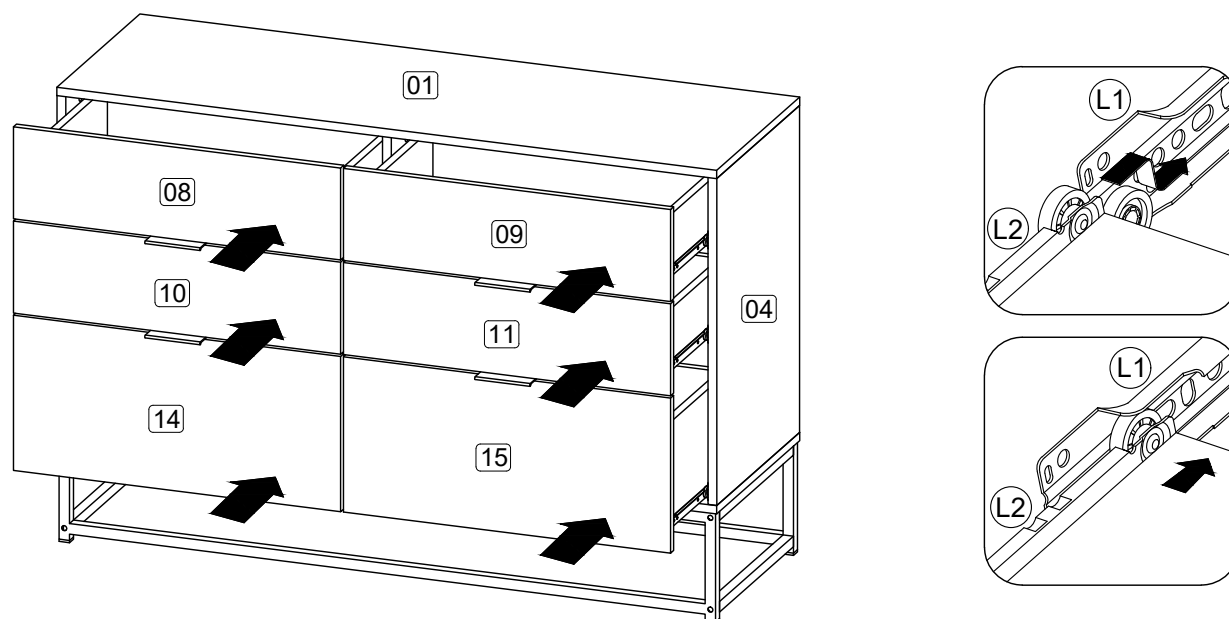

Step 13: To secure the item to the wall use hardware G, M and N using a screwdriver (not provided).

Then attach hardware part N to top panel (1) using hardware F with a screwdriver (not provided).

DO NOT use any power tools as this may damage the frame and will invalidate any claim.

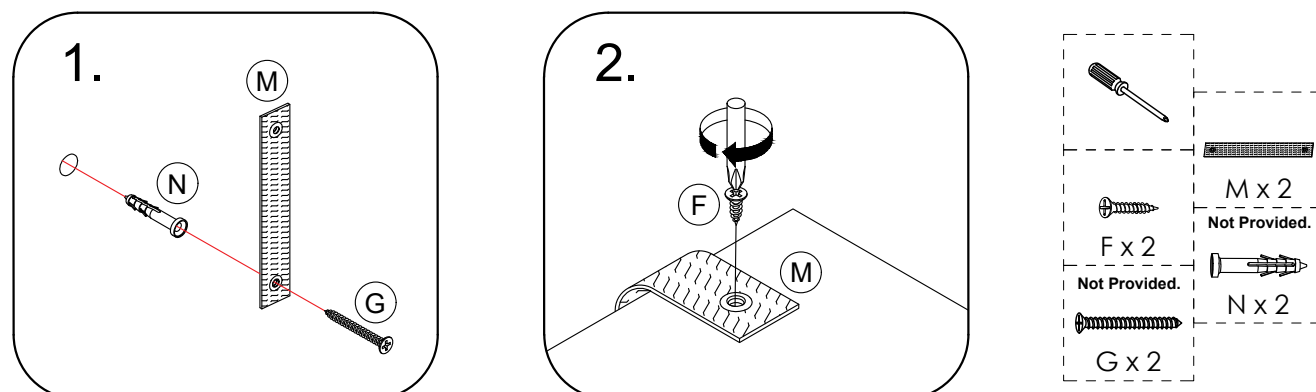

PLEASE NOTE that wall fixings are not supplied as different wall materials require different fixing devices. You must use fixings devices suitable for the type of wall you intend to mount product to. Ensure the head of any screw used has a diameter greater than the mounting hole and the fixing is safe and secure before use.

Birlea Furniture advise you use the wall straps provided to further enhance the safety of this product.

Additional Information:

- For complete product information, images and dimension diagrams please visit the website www.birlea.com
- If you have any issues with your item please contact the retailer directly you purchased it from who will be able to resolve any issues with Birlea.
- Why don't you send us photos of your assembled furniture to info@birlea.com to be shared in our #birleahome feature on instagram.



Birlea

Suppliers of inspiration