

# Birlea®

## Assembly Instructions

---

Thank you for purchasing a Birlea product.

For a chance to win a Love 2 Shop voucher simply post a picture of your new product on your preferred social channels tagging Birlea Furniture and using the hashtag #ShareYourStyle and #Birlea. One winner will be selected at random each month.

To view our full terms and conditions please visit our website. [www.birlea.com](http://www.birlea.com)

---

### Are you happy with your purchase?

**Yes:** That's great, we would love to hear more from you. Please leave us a review on our social media channels or Trustpilot. Your feedback will be greatly appreciated.

**No:** If for any reason there is something missing, indifferent or incorrect with your order, please contact the retailer you purchased the item from. We will work with the retailer to resolve your issue as quickly as possible.



[www.birlea.com](http://www.birlea.com)

## ASSEMBLY INSTRUCTIONS OLIVIA CORNER DRESSING TABLE WITH STORAGE

**IMPORTANT: READ THESE INSTRUCTIONS CAREFULLY BEFORE ASSEMBLING OR USING YOUR OLIVIA CORNER DRESSING TABLE WITH STORAGE**

**PLEASE KEEP THESE INSTRUCTIONS FOR FUTURE REFERENCE.**

### **HEALTH & SAFETY:**

DO NOT use this item if any parts are missing, damaged or worn.  
DO NOT use this item unless all fixings are secured.  
Please keep small parts out of reach of children  
Always use on a level, even surface.

### **CARE & MAINTENANCE:**



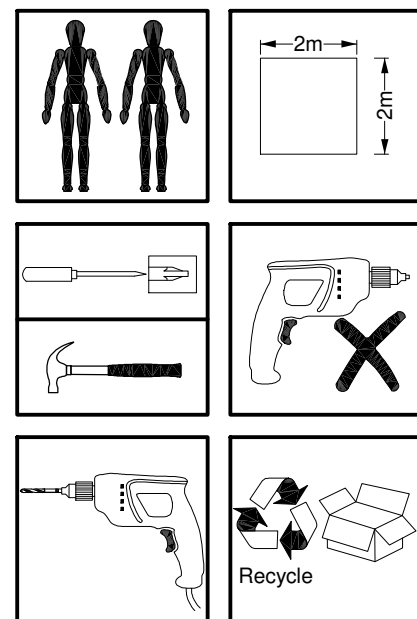
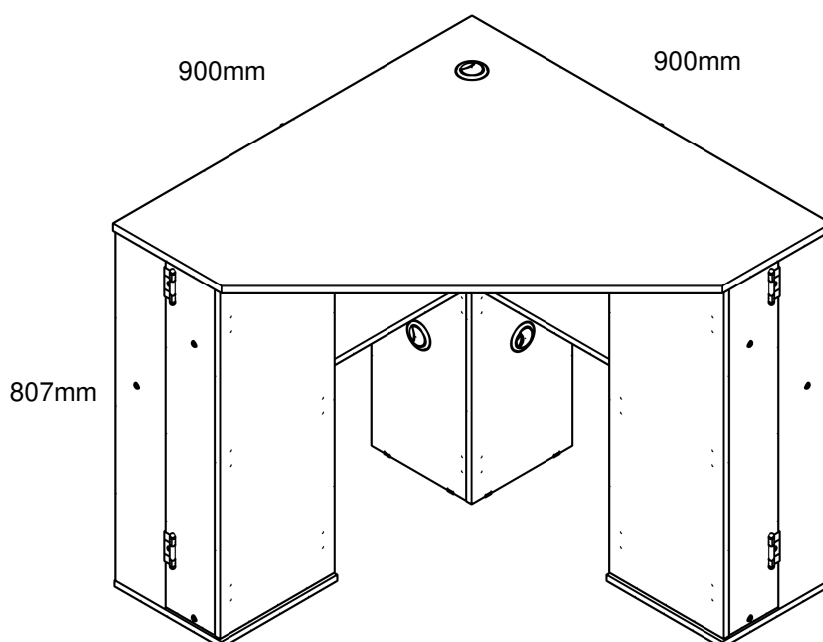

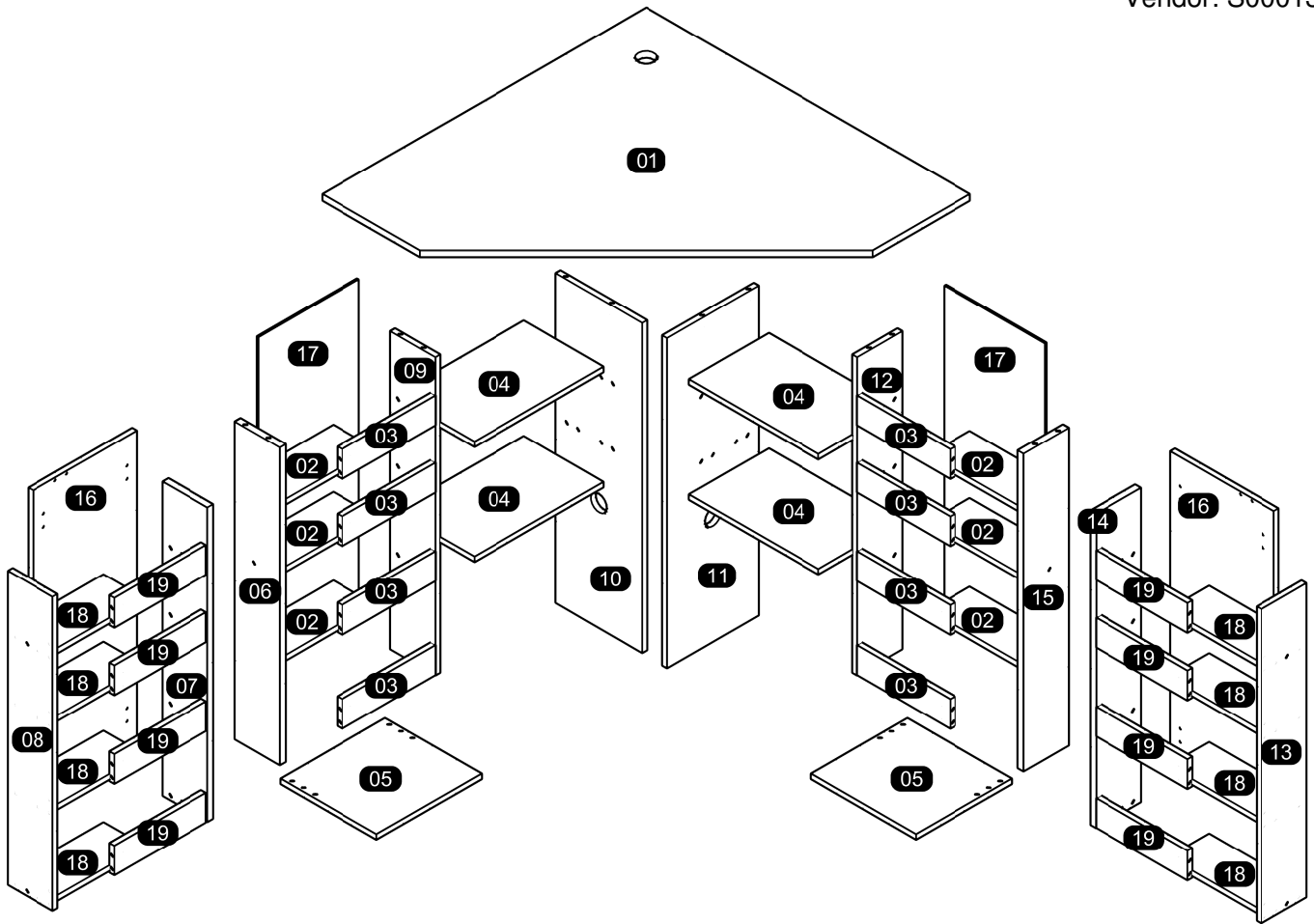





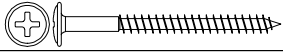
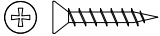
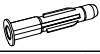

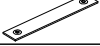

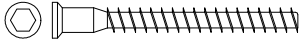

Assemble in the room of use  
Assembly should be carried out with this item laying flat, not standing upright.  
Assemble on a soft, clean surface to prevent damages.  
To remove the printed numbers on the pieces, use the eraser provided  
Periodically check all screws & fixings to ensure they are secure.  
DO NOT push the item as this will damage the base.  
Always lift the item with two people to reposition.  
Keep any sharp objects away from the item.



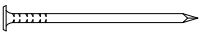

### Parts List

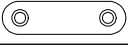
Part	Description	Box	Qty
01	Top Panel	1	1
02	Side Shelf	1	6
03	Side Crossbar	1	8
04	Shelf	1	4
05	Base Panel	1	2
06	Left Side Fixed Module Left	1	1
07	Left Side Door Module Left	1	1
08	Right Side Door Module Left	1	1
09	Left Division	1	1
10	Left Panel	1	1
11	Right Panel	1	1
12	Right Division	1	1
13	Left Side Door Module Right	1	1
14	Right Side Door Module Right	1	1
15	Right Side Fixed Module Right	1	1
16	Front Door	1	2
17	Back Panel	1	2
18	Side Shelf	1	8
19	Side Crossbar	1	8

Hardware List		
Part	Description	Qty
A	5,0 x 60 mm Screw	 2
A8	3,5 x 20 mm Screw	 8
B3	Wall Plug	 2
B5	Metalic Angle Plates	 14
E9	Strap	 2
F1	6 x 30 mm Wooden Dowel	 156
G	Structural Screw	 28
H	Allen Key	 1
H13	Smal Plastic Foot	 4
I	Structural Screw Cover	 12
L4	Plastic Foot	 8
L9	3,5x12 mm Screw	 114
N	10 x 10 mm Tack	 44
P6	Cable Tidy Grommet	 3
S	3,5 x 14 mm Screw	 4
V15	Magnetic Closure	 2
V16	Metalic Plate	 2
Y18	Zamac Bracket	 12
Y2	Metal Hinge	 4

**\*\* You will need a small mallet and a screwdriver for assembly.**

**\*\* Some screws and wooden dowel may remain.**

**\*\* Wall plug and screw is supplied to attach strap to the wall.**

**Step 1:** Insert hardware part V15 using hardware part S and screwdriver (not provided).  
**DO NOT use any power tools as this may damage the frame and will invalidate any claim.**

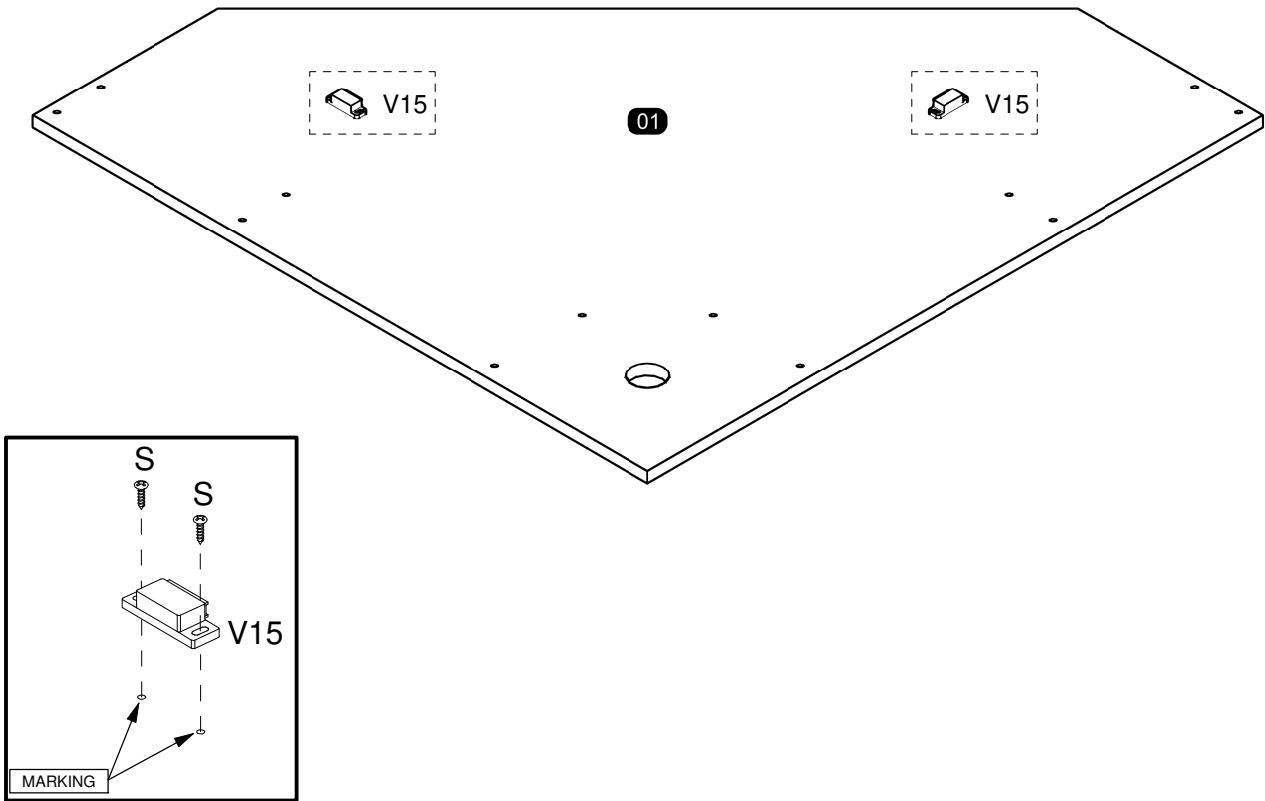

**Step 2:** Insert hardware part F1 using small mallet (not provided).  
**DO NOT use any power tools as this may damage the frame and will invalidate any claim.**

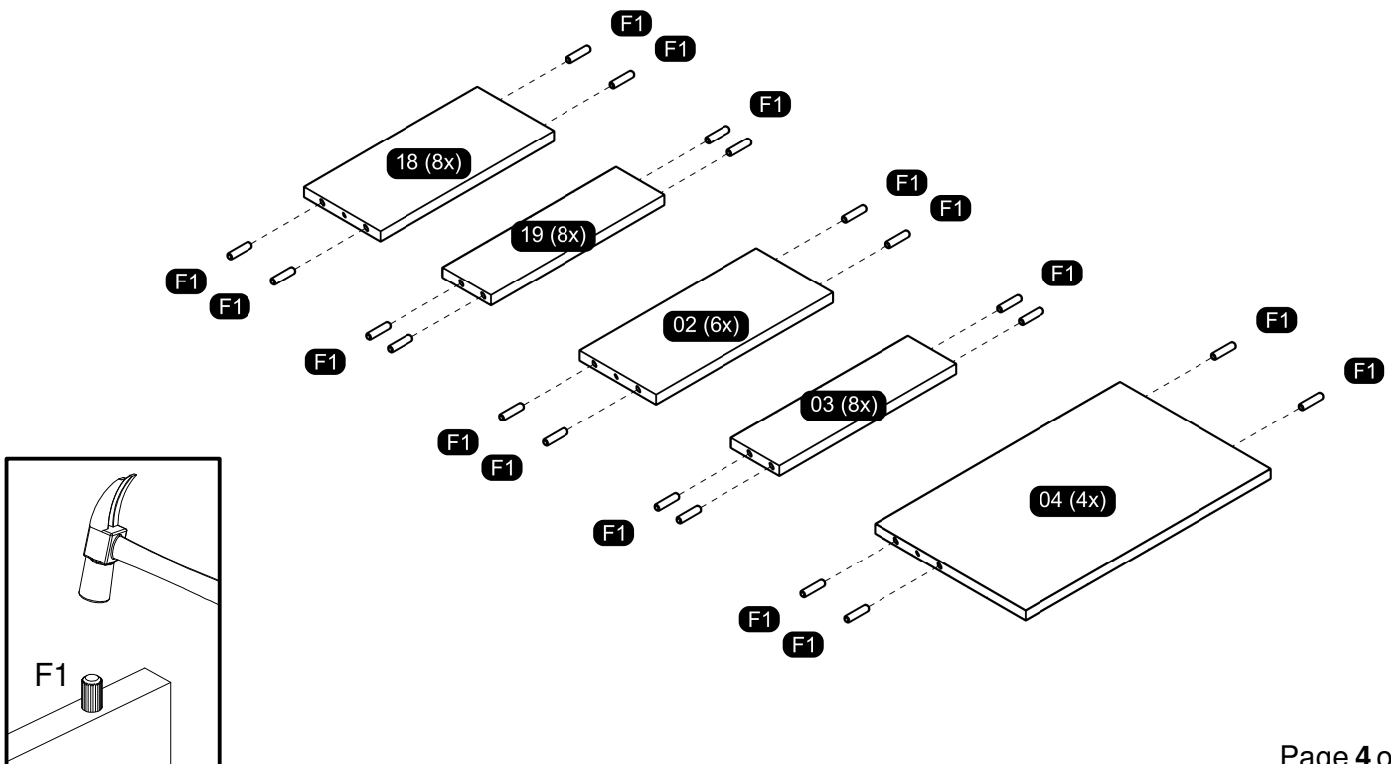

**Step 3:** Insert hardware part F1 using small mallet (not provided).  
**DO NOT use any power tools as this may damage the frame and will invalidate any claim.**

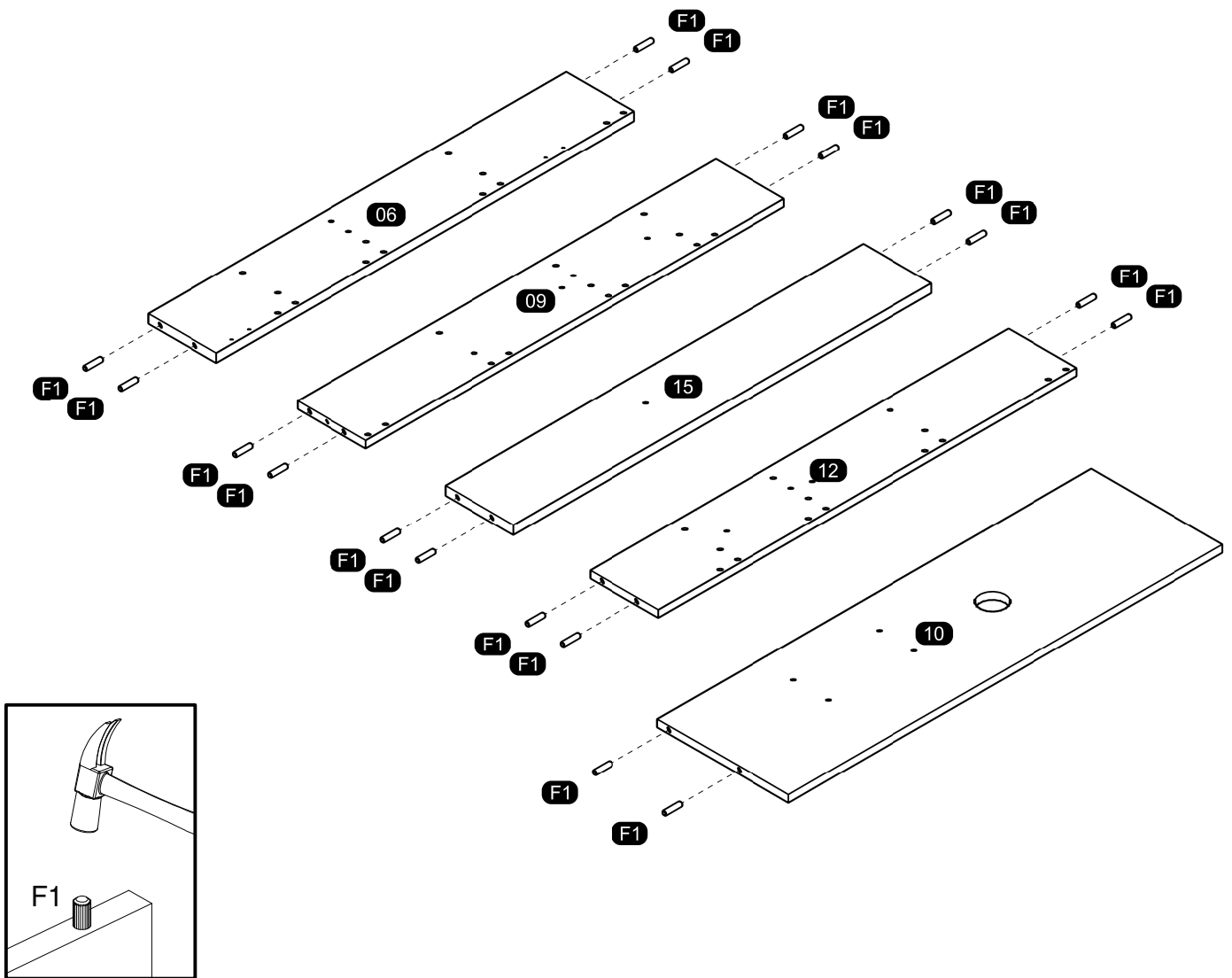

**Step 4:** Insert hardware part F1 using small mallet (not provided).  
Insert hardware part B5 using hardware part L9 and screwdriver (not provided).  
**DO NOT use any power tools as this may damage the frame and will invalidate any claim.**

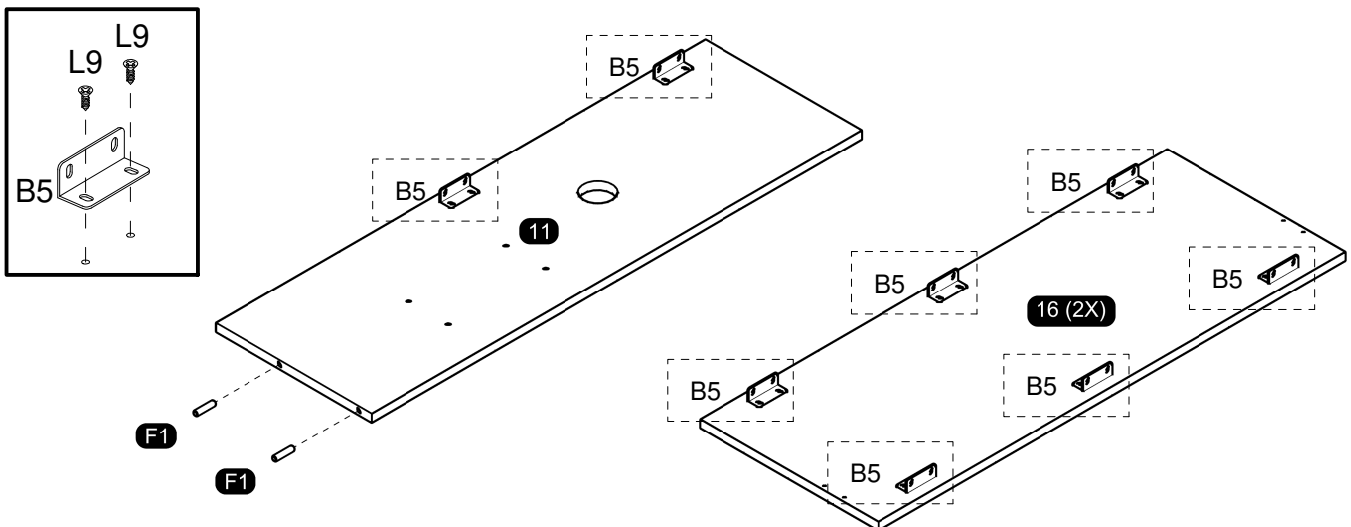

**Step 05:** Attach the shelf (04), left division (09) and left panel (10) using the hardware G and H.  
**DO NOT use any power tools as this may damage the frame and will invalidate any claim.**

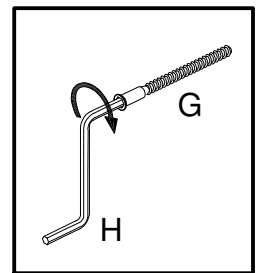
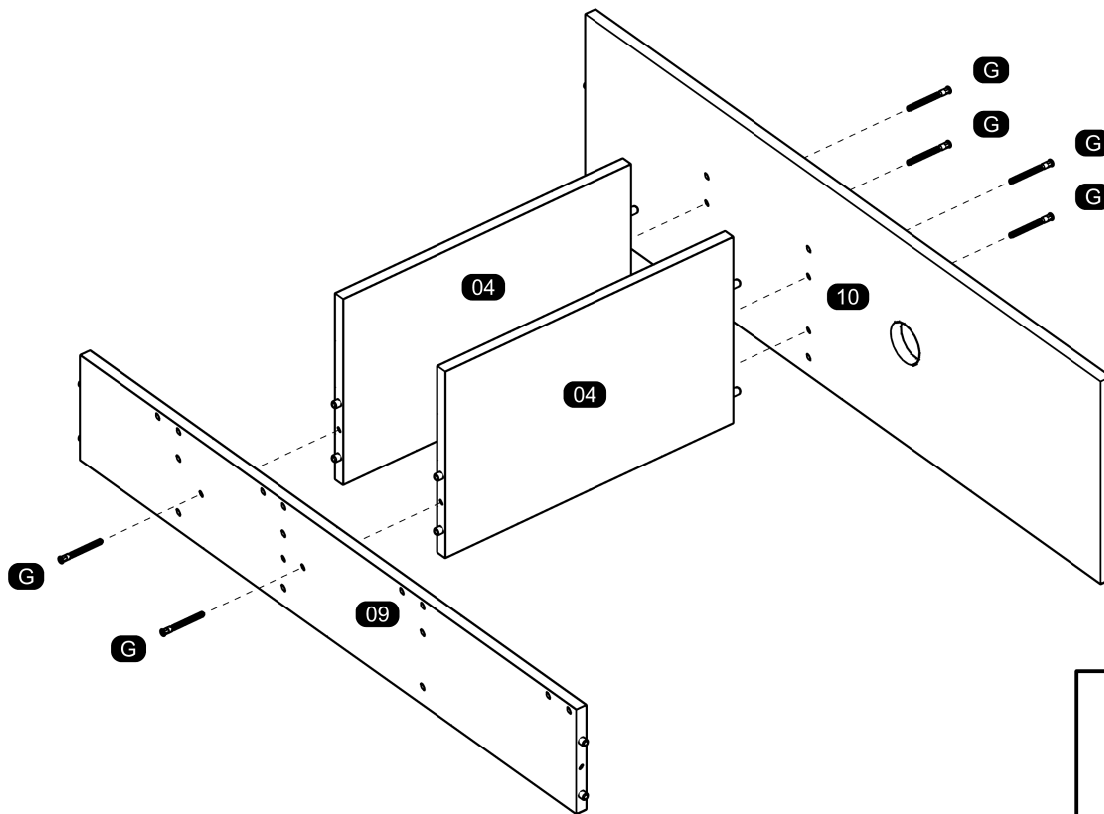

**Step 06:** Join the side shelf (02) to the assembled section using the hardware G, H and I.  
**DO NOT use any power tools as this may damage the frame and will invalidate any claim.**

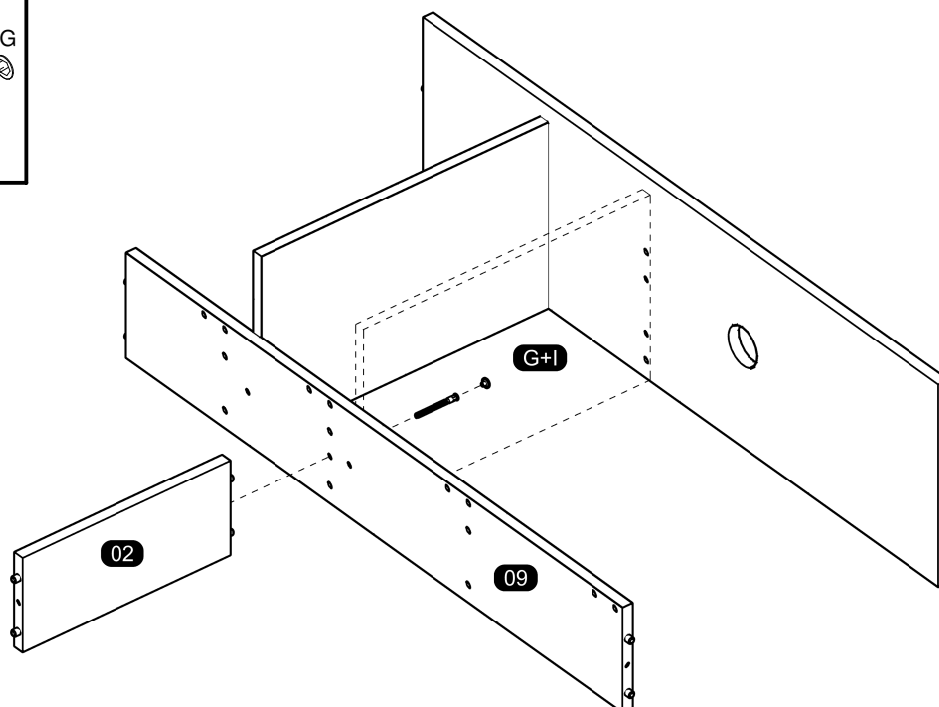
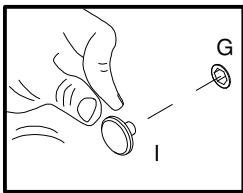

**Step 07:** Join the side shelf (02) to the assembled section.  
**DO NOT use any power tools as this may damage the frame and will invalidate any claim.**

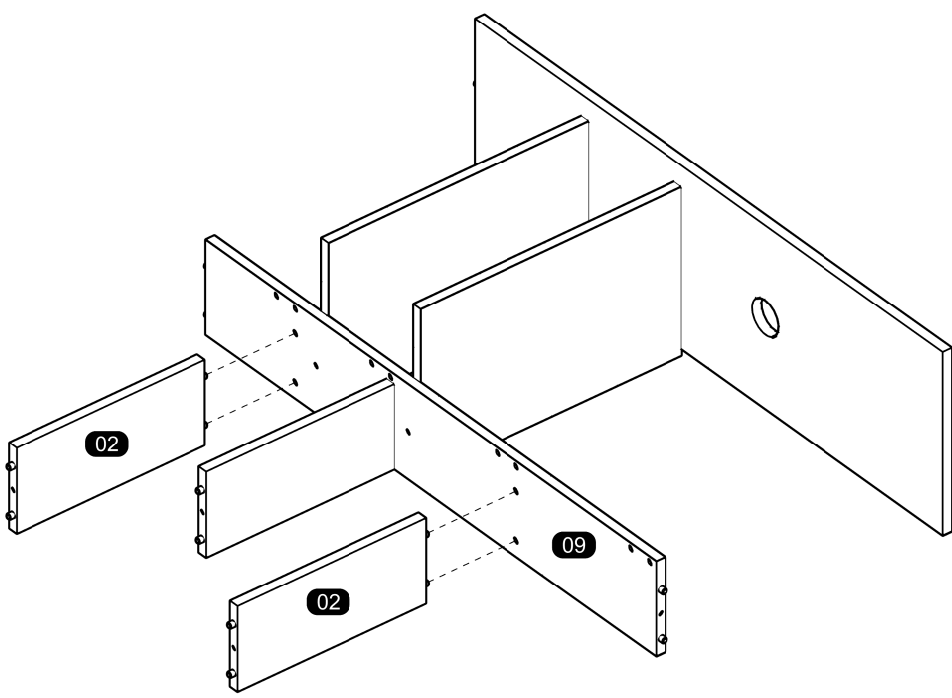

**Step 08:** Join the left side fixed module left (06) and side crossbar (03) to the assembled section using the hardware G, H and I.  
**DO NOT use any power tools as this may damage the frame and will invalidate any claim.**

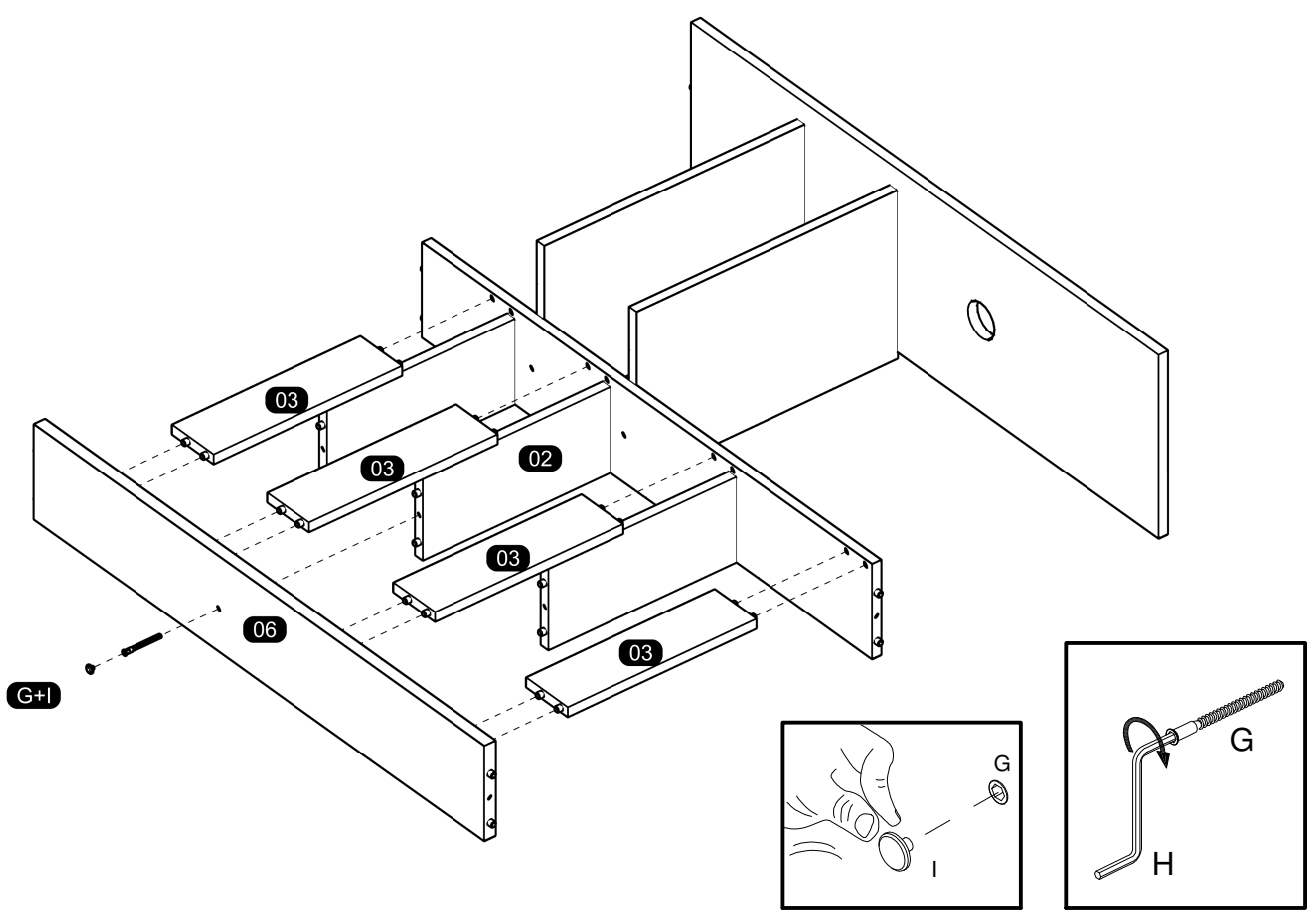



**Step 09:** Join the base panel (05) to the assembled section using the hardware G, and H.  
**DO NOT use any power tools as this may damage the frame and will invalidate any claim.**

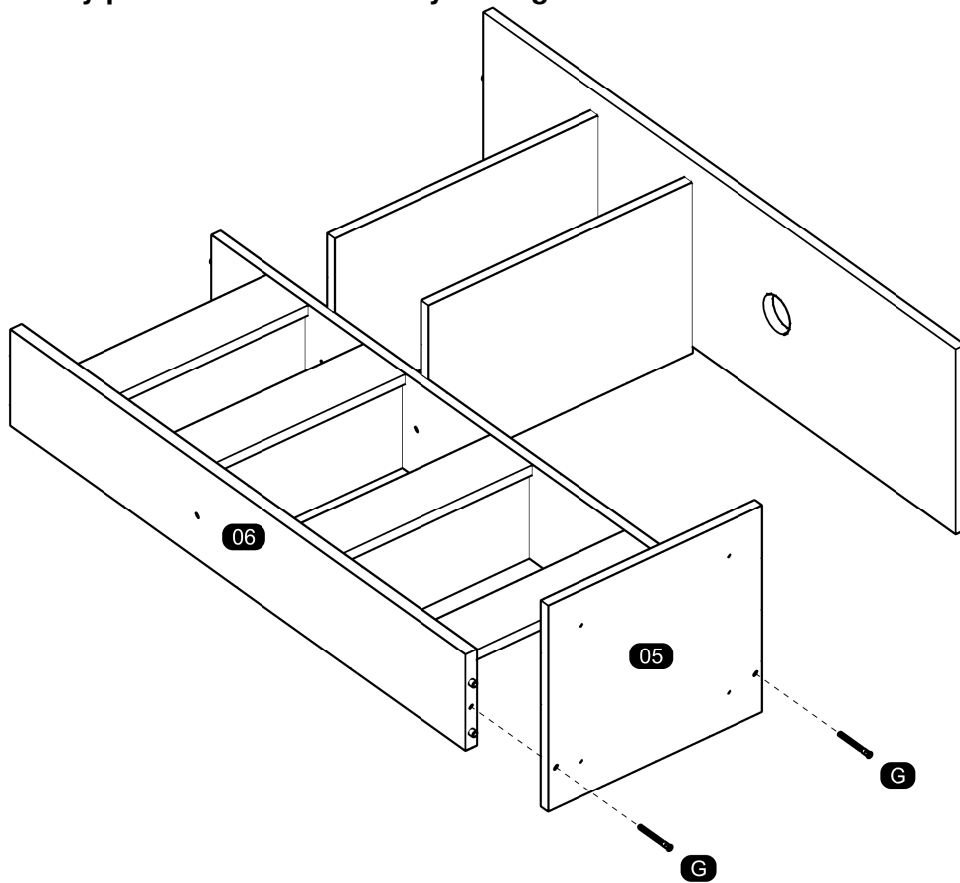

**Step 10:** Insert hardware part H13 using part N using small mallet (not provided).  
 Insert hardware part L4 using part A8 using screwdriver (not provided).  
**DO NOT use any power tools as this may damage the frame and will invalidate any claim.**

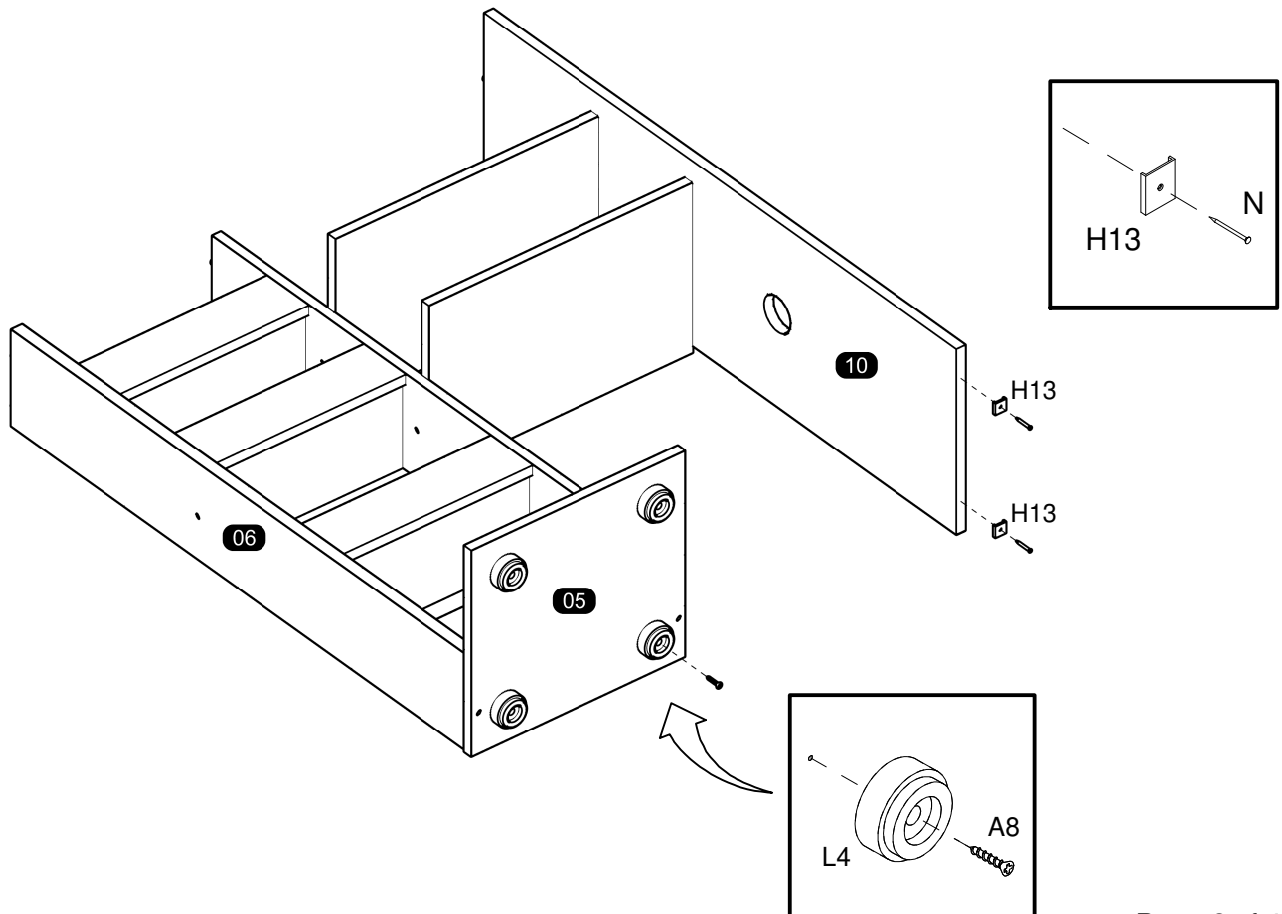

**Step 11:** Attach the shelf (04), right panel (11) and right division (12) using the hardware G and H.  
**DO NOT use any power tools as this may damage the frame and will invalidate any claim.**

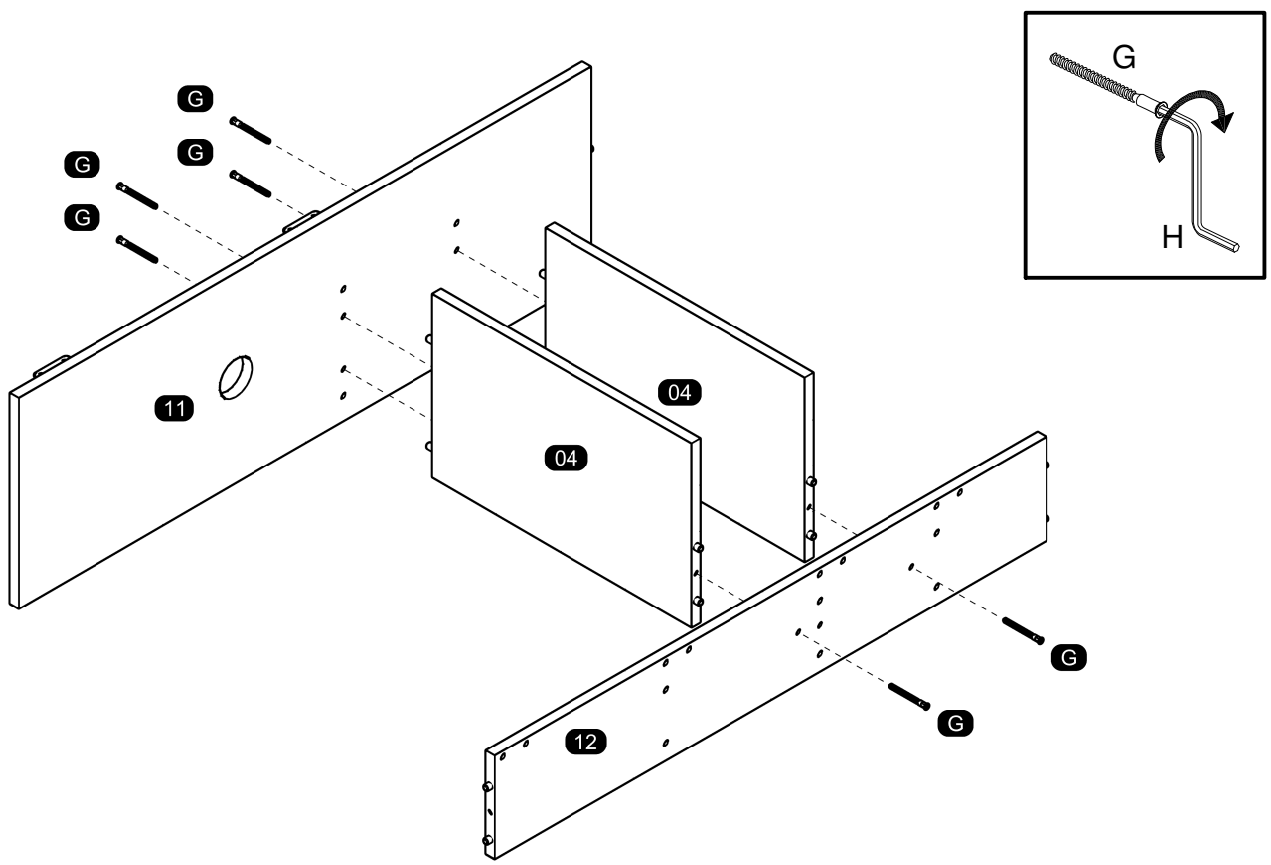

**Step 12:** Join the side shelf (02) to the assembled section using the hardware G, H and I.  
**DO NOT use any power tools as this may damage the frame and will invalidate any claim.**

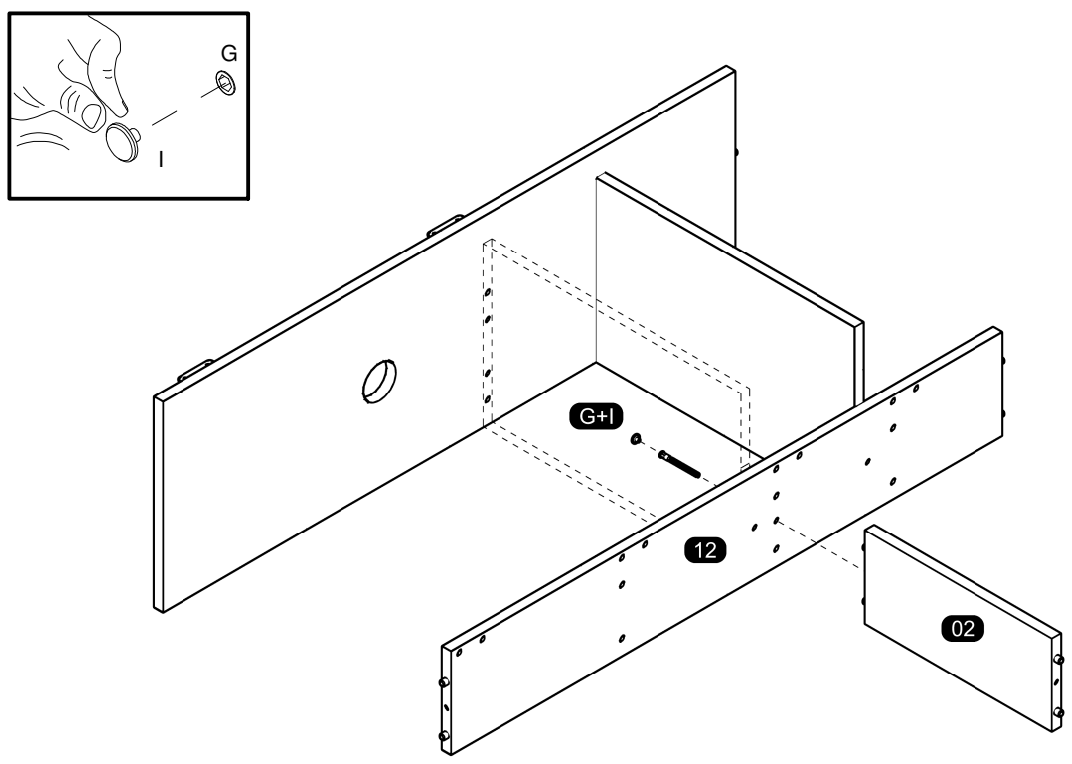

**Step 13:** Join the side shelf (02) to the assembled section.

**DO NOT use any power tools as this may damage the frame and will invalidate any claim.**

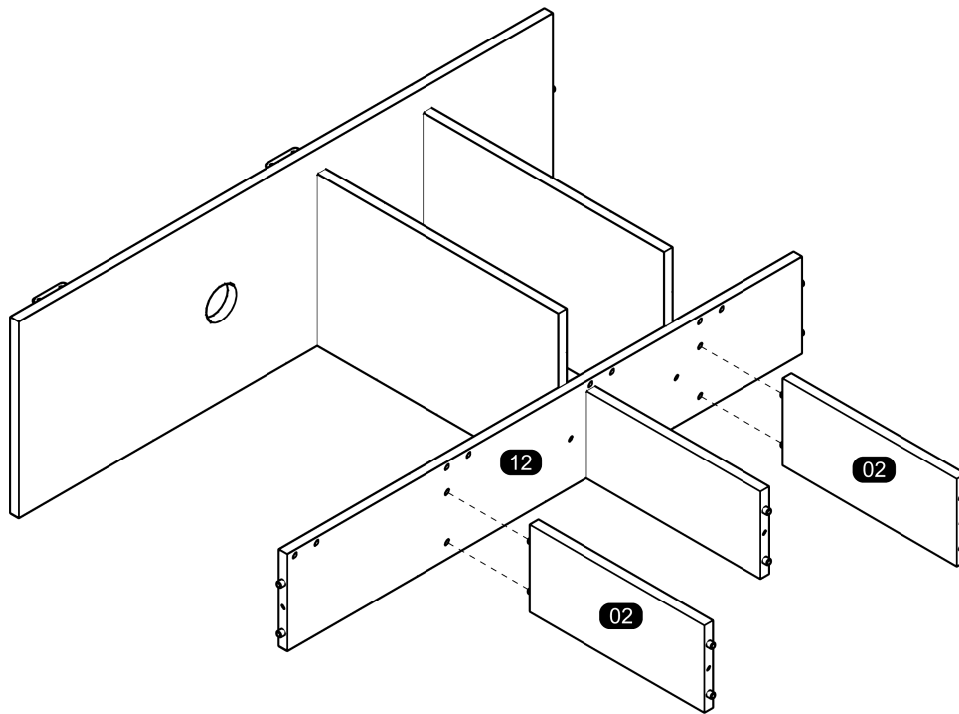

**Step 14:** Join the right side fixed module right (15) and side crossbar (03) to the assembled section using the hardware G, H and I.

**DO NOT use any power tools as this may damage the frame and will invalidate any claim.**

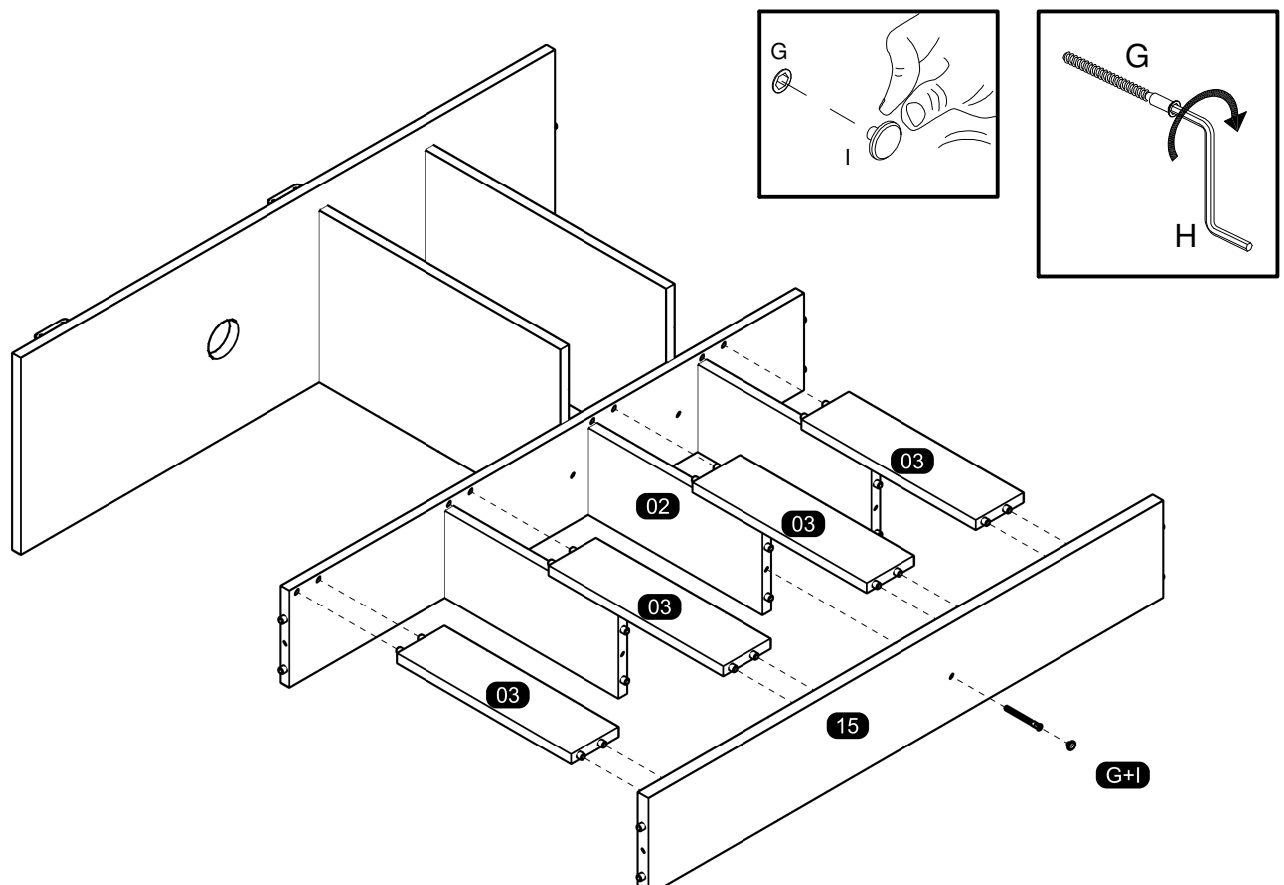

**Step 15:** Join the base panel (05) to the assembled section using the hardware G, and H.  
**DO NOT use any power tools as this may damage the frame and will invalidate any claim.**

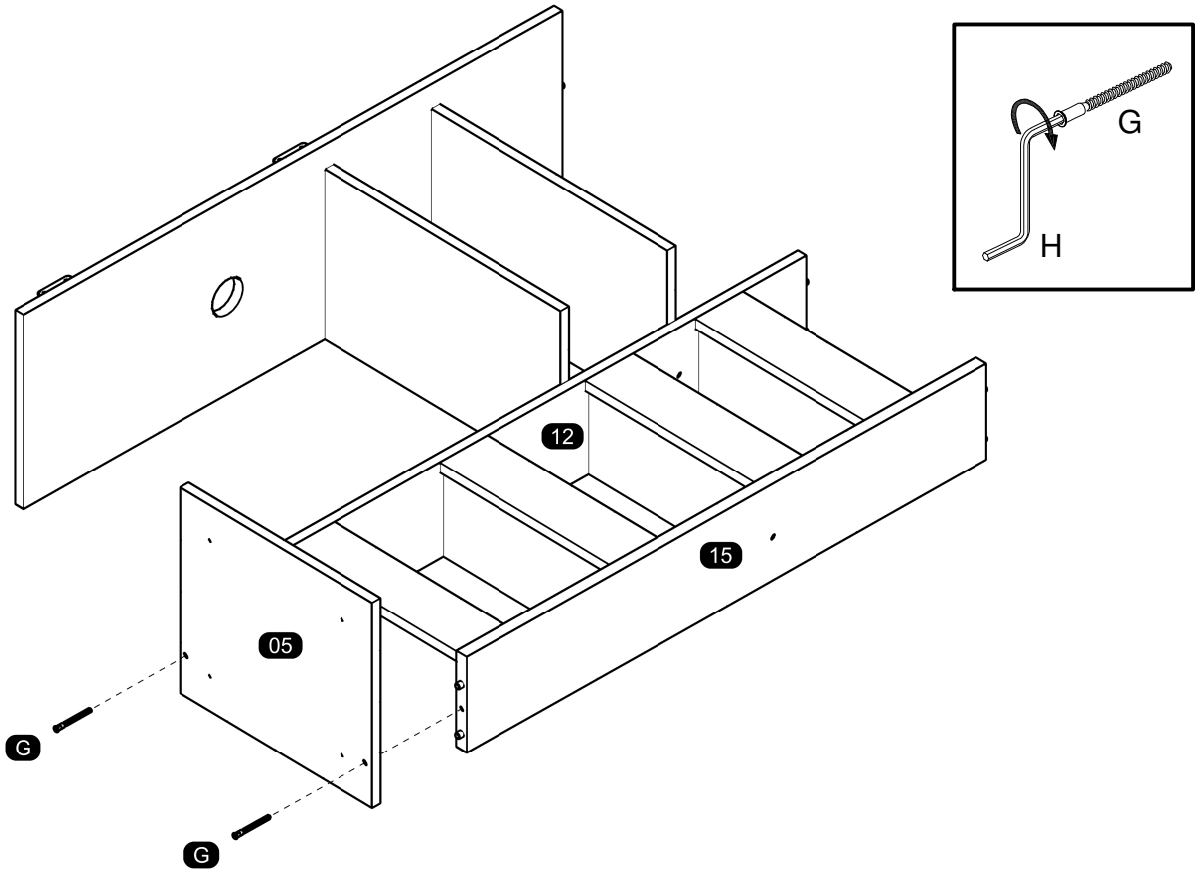

**Step 16:** Insert hardware part H13 using part N using small mallet (not provided).  
Insert hardware part L4 using part A8 using screwdriver (not provided).  
**DO NOT use any power tools as this may damage the frame and will invalidate any claim.**

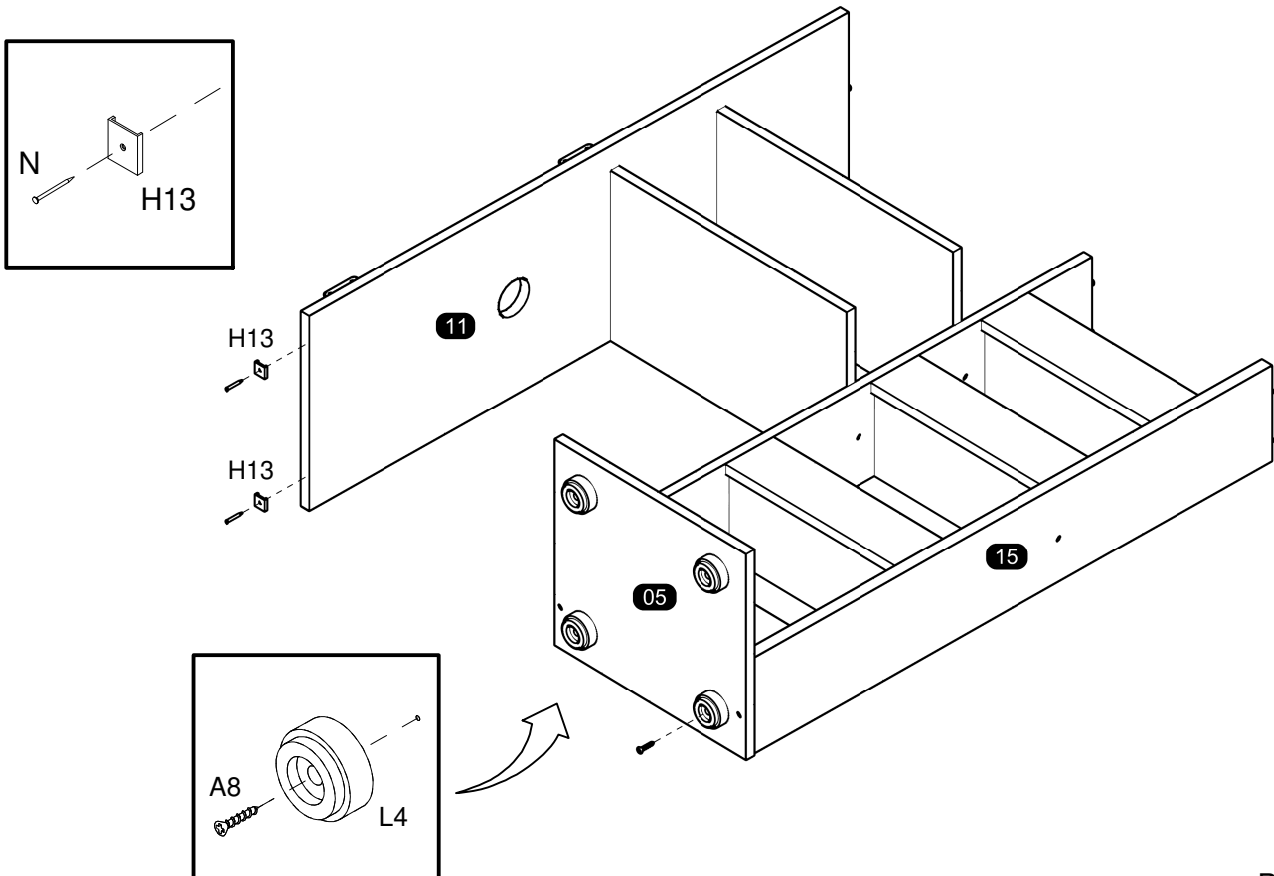

**Step 17:** Join the top panel (01) to the assembled section using the hardware Y18, L9 and screwdriver (not provided).

Attach the hardware part B5 using part L9 using screwdriver (not provided).

**DO NOT use any power tools as this may damage the frame and will invalidate any claim.**

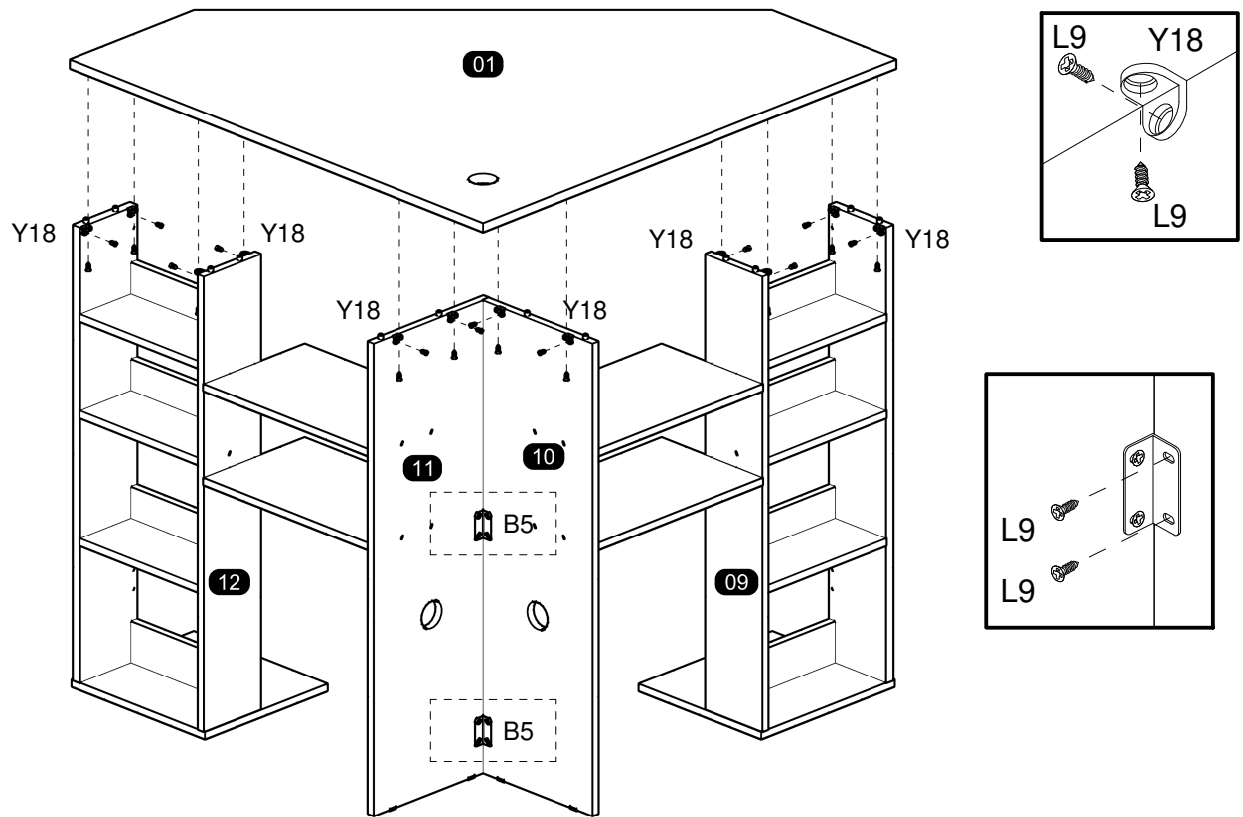

**Step 18:** Attach the back panel (17) to the assembled section using hardware part N using a small mallet (not provided).

**DO NOT use any power tools as this may damage the frame and will invalidate any claim.**

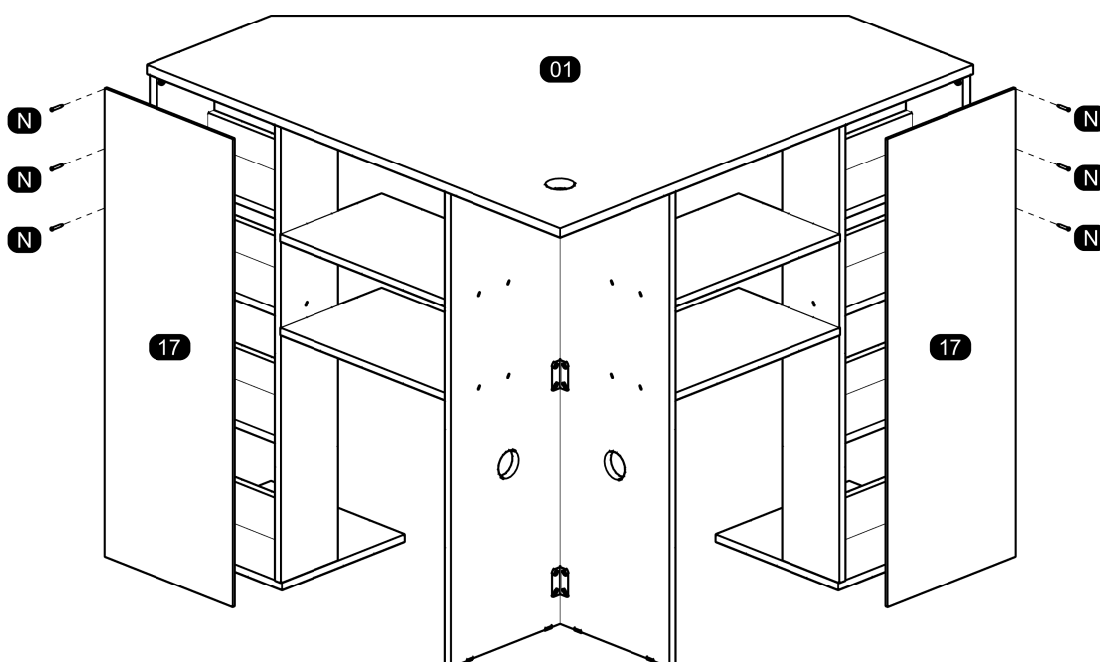

**Step 19:** To secure the item to the wall use hardware parts E9, B3 and A using a screwdriver (not provided). Then attach hardware part L9 to the item with a screwdriver (not provided).

**Birlea Furniture advise you use the wall straps provided to further enhance the safety of this product**

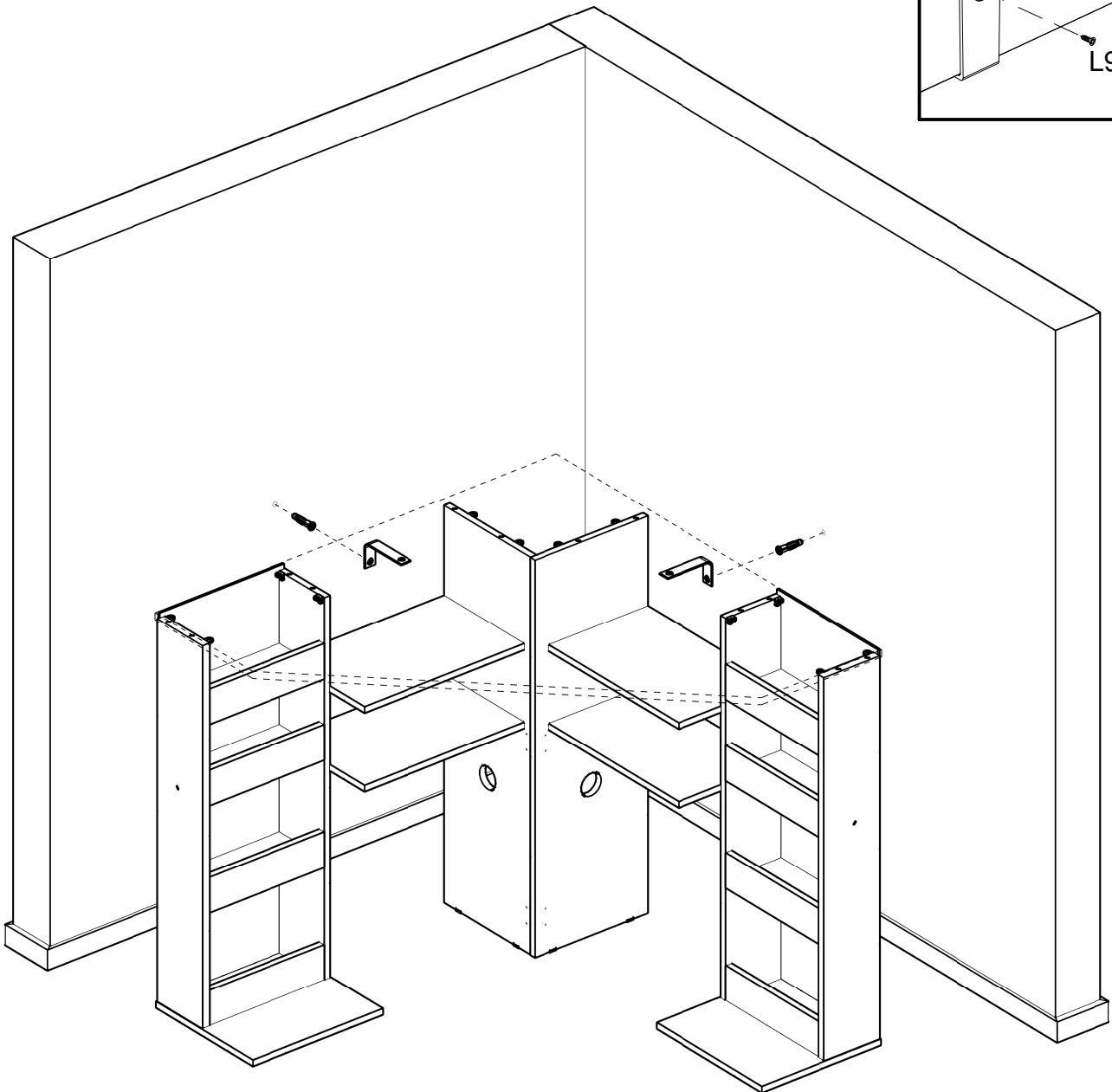
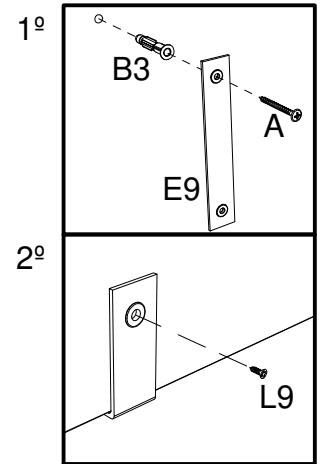

**Step 20:** Attach the left side door module right (13) and side shelf (18) using the hardware G, H and I.  
**DO NOT use any power tools as this may damage the frame and will invalidate any claim.**

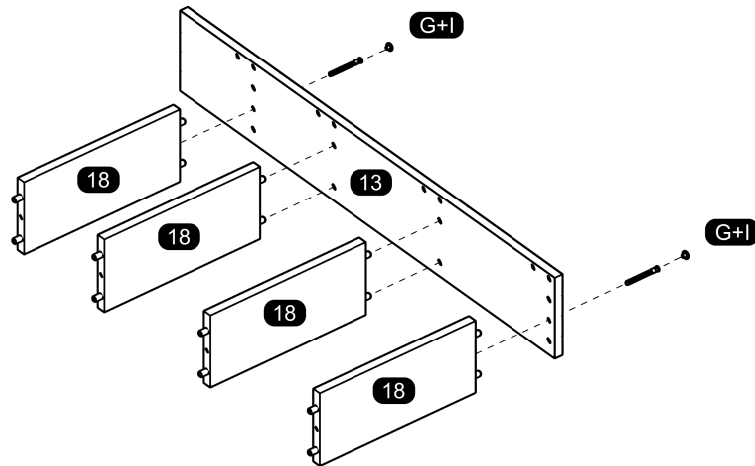

**Step 21:** Attach the right side door module right (14) and side crossbar (19) using the hardware G, H and I.  
**DO NOT use any power tools as this may damage the frame and will invalidate any claim.**

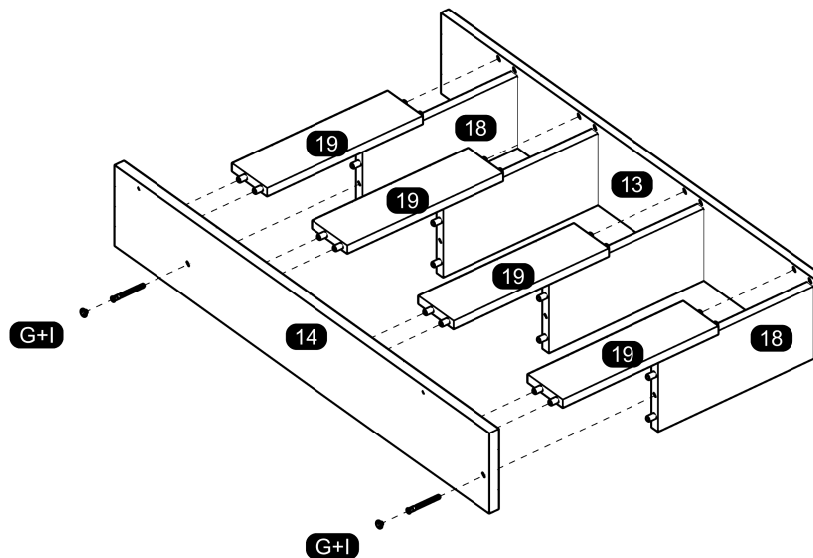
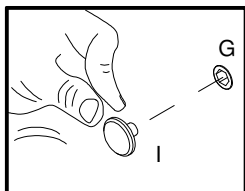
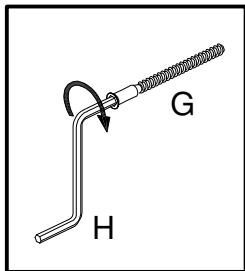

**Step 22:** Attach the front door (16) to the assembled section using hardware part B5, L9 and screwdriver (not provided).

**DO NOT use any power tools as this may damage the frame and will invalidate any claim.**

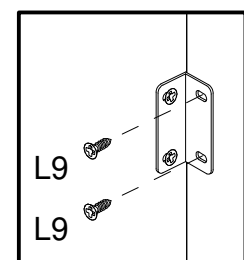
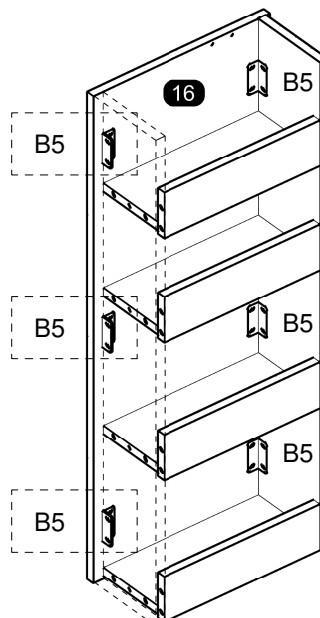

**Step 23:** Attach the left side door module left (07) and side shelf (18) using the hardware G, H and I.  
**DO NOT use any power tools as this may damage the frame and will invalidate any claim.**

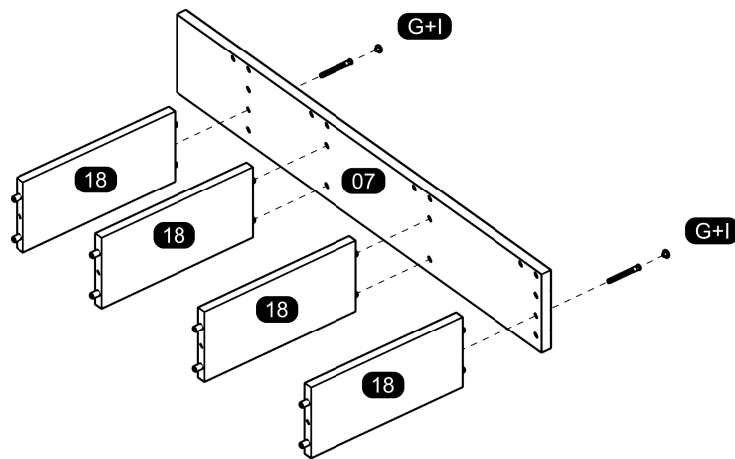

**Step 24:** Attach the right side door module left (08) and side crossbar (19) using the hardware G, H and I.  
**DO NOT use any power tools as this may damage the frame and will invalidate any claim.**

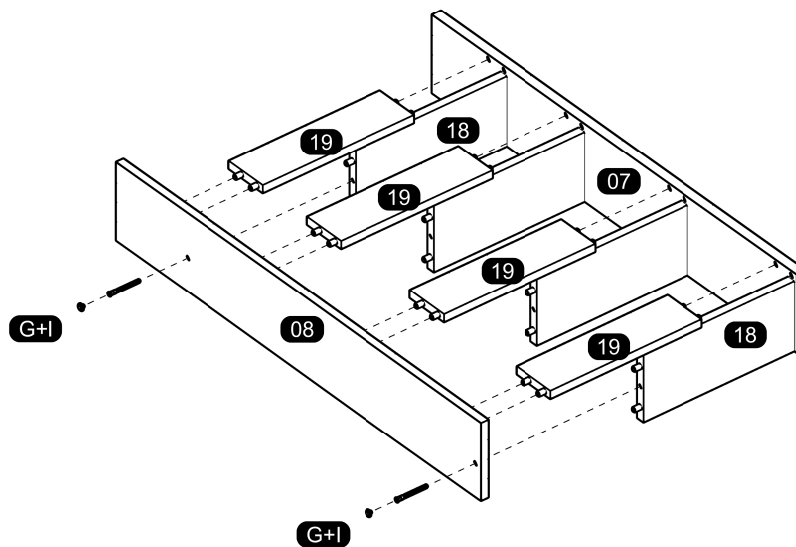
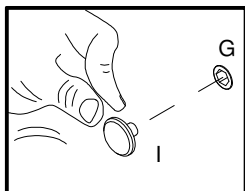
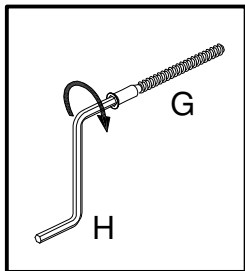

**Step 25:** Attach the front door (16) to the assembled section using hardware part B5, L9 and screwdriver (not provided).  
**DO NOT use any power tools as this may damage the frame and will invalidate any claim.**

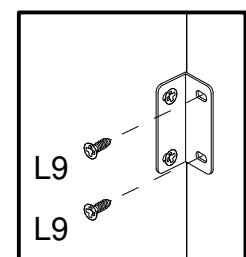
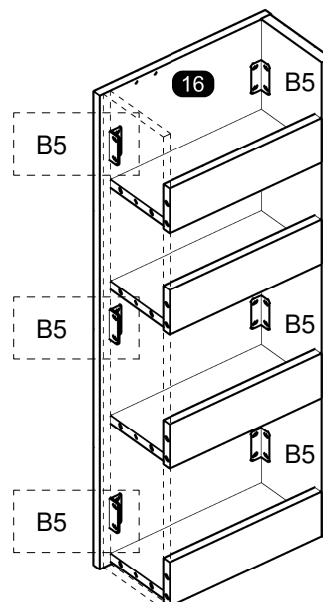



**Step 26:** Insert hardware part Y2 using part L9 using screwdriver (not provided).  
**DO NOT use any power tools as this may damage the frame and will invalidate any claim.**

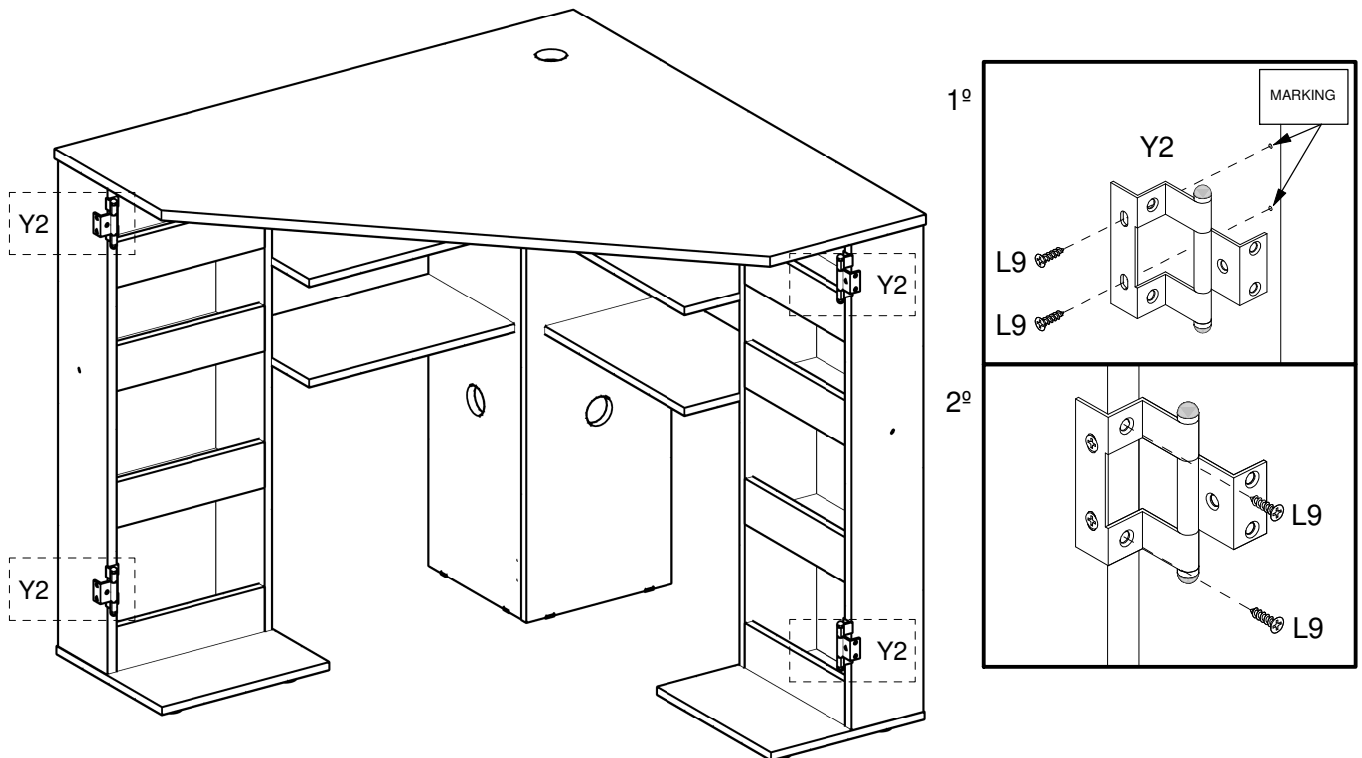

**Step 27:** Attach the left side door module left (07) and right side door module right (14) to the assembled section using hardware part Y2, L9 and screwdriver (not provided).  
**DO NOT use any power tools as this may damage the frame and will invalidate any claim.**

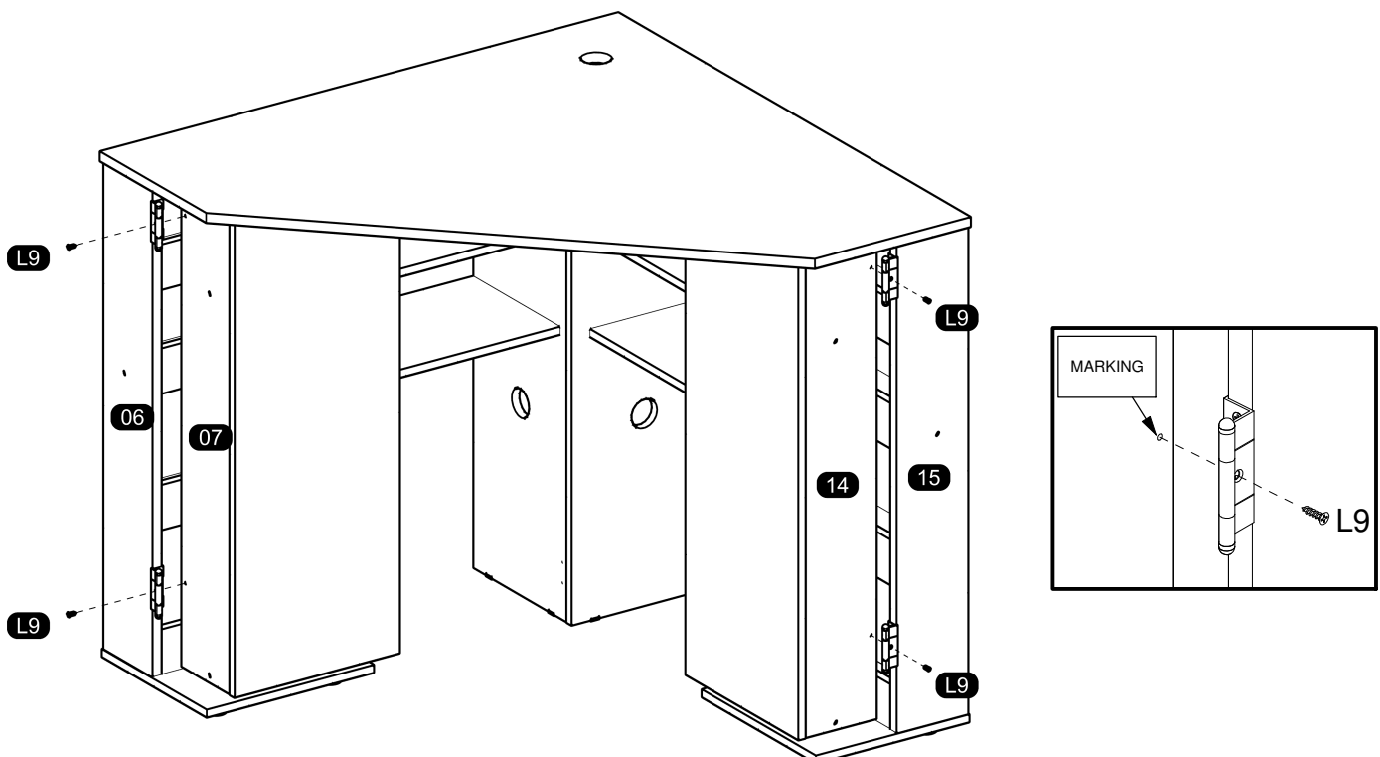

**Step 28:** Insert hardware part L9 using screwdriver (not provided).  
**DO NOT use any power tools as this may damage the frame and will invalidate any claim.**

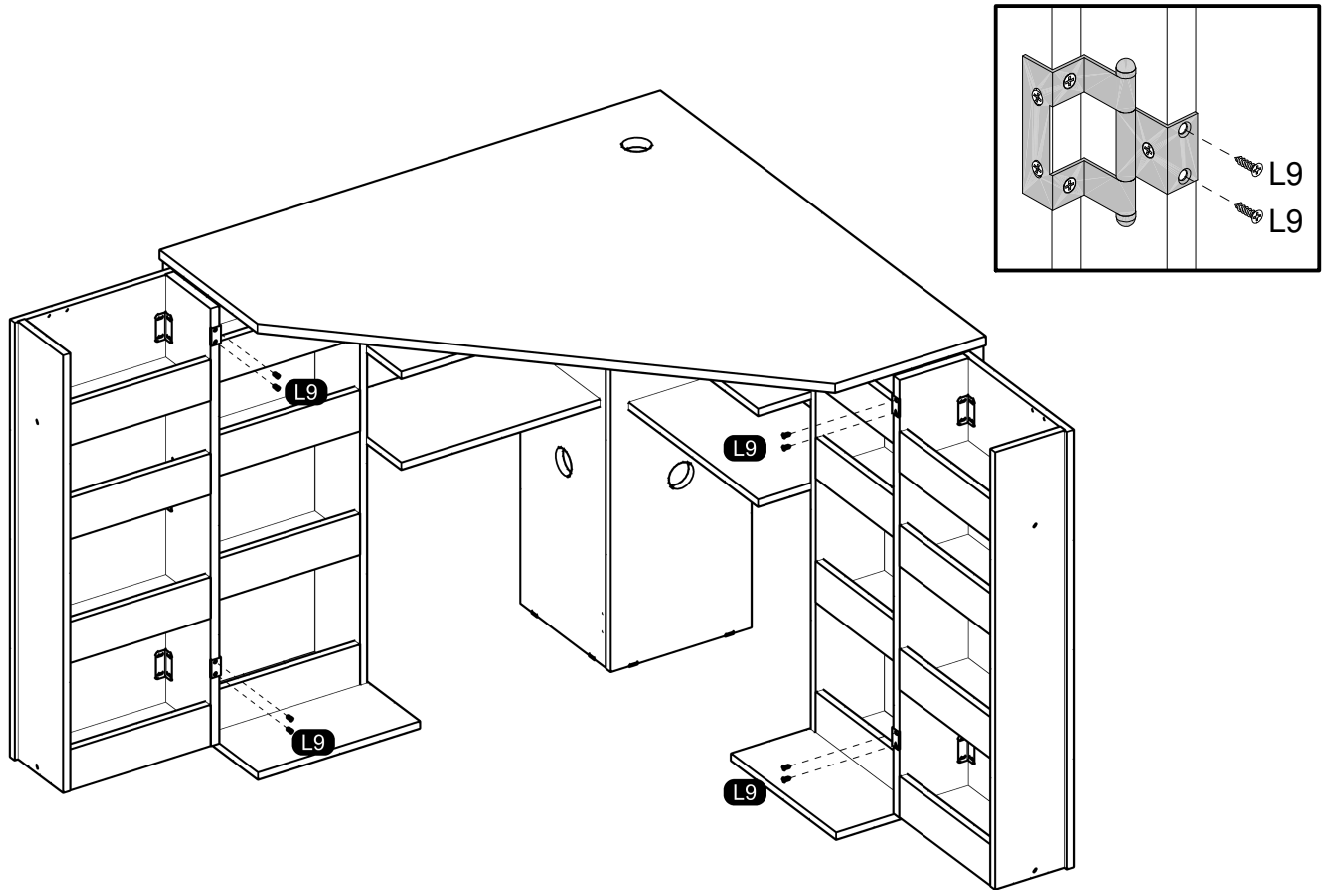

**Step 29:** Insert hardware part P6.  
Insert hardware part V16 using part L9 using screwdriver (not provided).  
**DO NOT use any power tools as this may damage the frame and will invalidate any claim.**

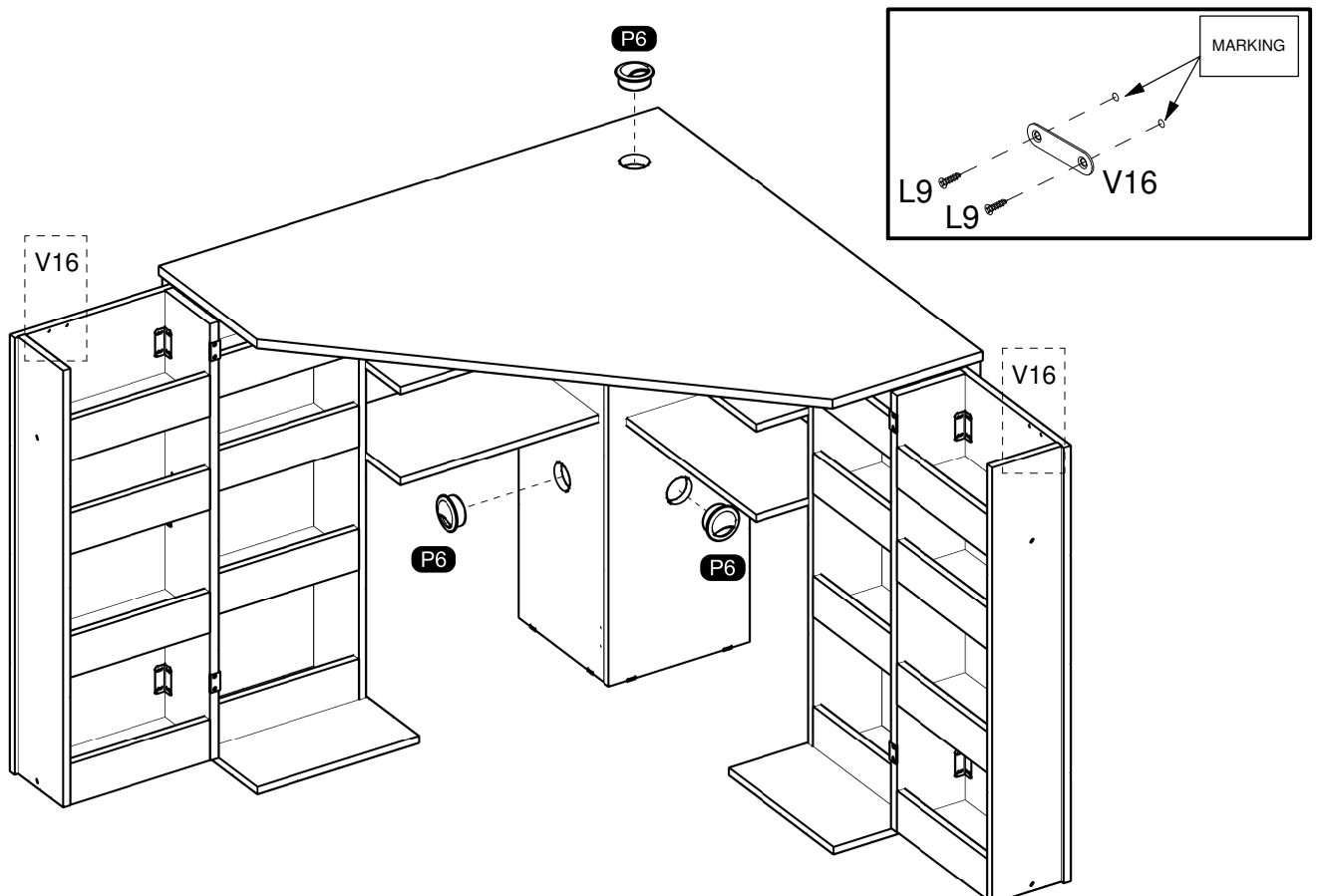

**Step 30: Rotate the doors**

**Birlea Furniture advise you use the wall straps provided to further enhance the safety of this product**

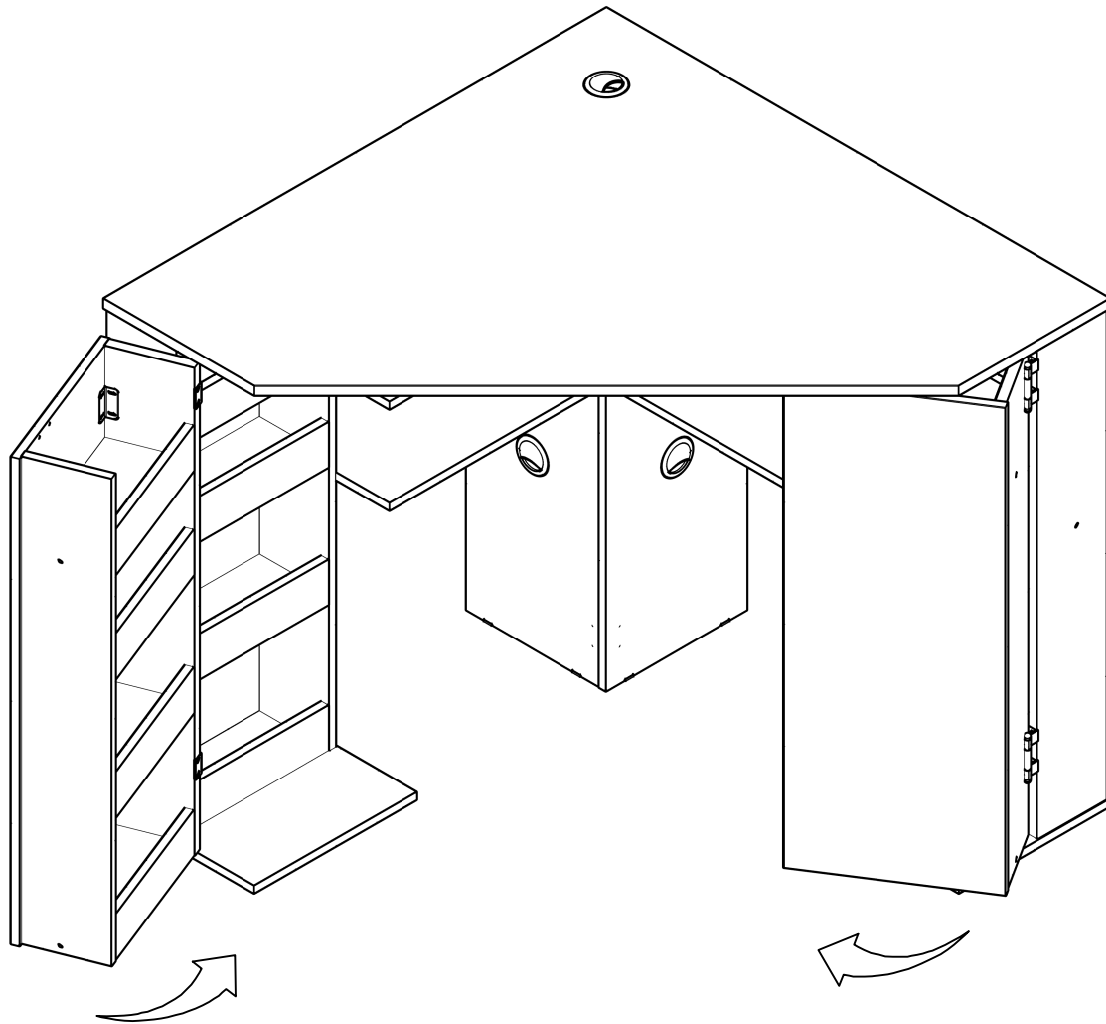

**Additional Information:**

- For complete product information, images and dimension diagrams please visit the website [www.birlea.com](http://www.birlea.com)
- If you have any issues with your item please contact the retailer directly you purchased it from who will be able to resolve any issues with Birlea.
- Why don't you send us photos of your assembled furniture to [info@birlea.com](mailto:info@birlea.com) to be shared in our #birleahome feature on Instagram.

**Birlea**<sup>®</sup>